



Modelling Energy Saving Potential in Industry.

Case of the Steel and Paper Industries

...Study optic



- *Modelling the Long range Energy needs and potential energy savings in European industry*
- *EDF R&D / CMA Program*

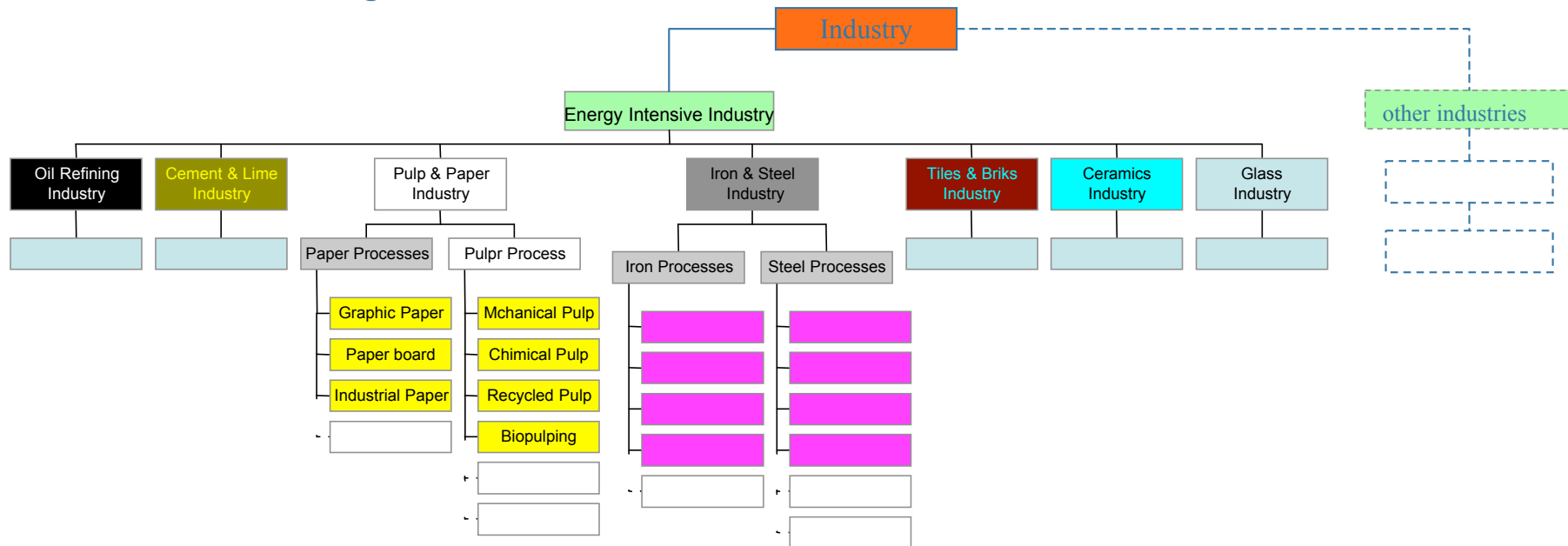

- *TIMES Model tools*

...TIMES Model



The Integrated MARKAL-EFOM System

Created by ETSAP members - 1997

Current users: CMA, IER, VTT, Italy...

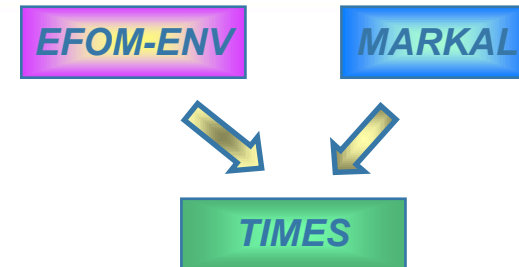

$$\text{Max} \left\{ \int_{d_0}^d p(q) dq - c^t \cdot x \right\} \quad \text{objective function : NPV of net surplus}$$

s.t. $Ax - d \geq 0$ satisfaction of demands

$Ex \leq e$ cap on emissions

$Bx \geq b$ financial, logical, and technical constraints

$UB \geq x \geq LB$ optional bounds

x : decision variables : investments, capacities, activities, of technologies,
amounts of commodities produced, consumed, traded

d : variables : demands for products and services

1: *TIMES Documentation, R. Loulou et Al., 2005*

...TIMES Reference Energy System (RES)

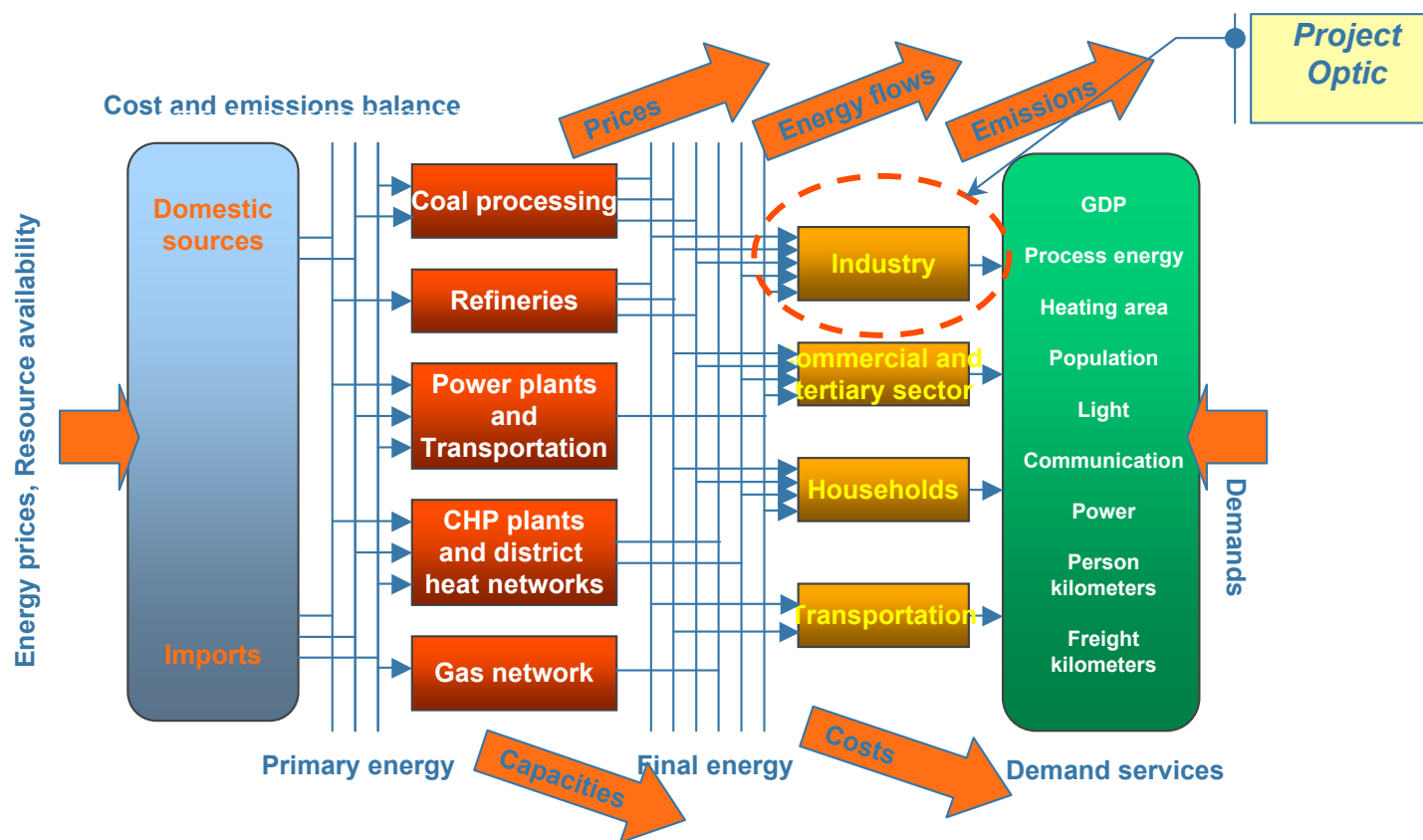

Source: IER

4-9 June Colle sur Loup
A. Djemaa

EDF R&D / CMA, ECEEE Summer
Study 2007

4/25

...RES Industry

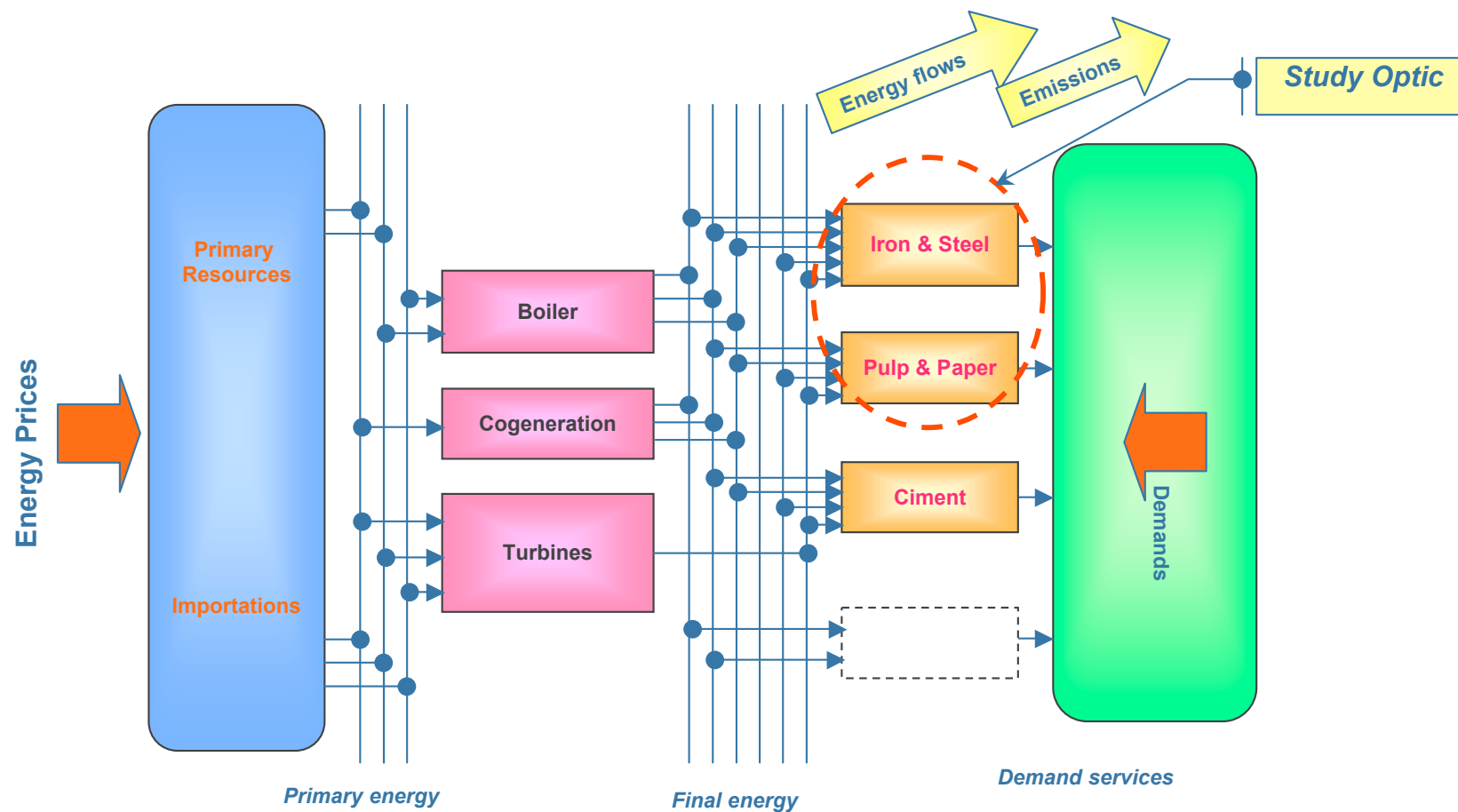

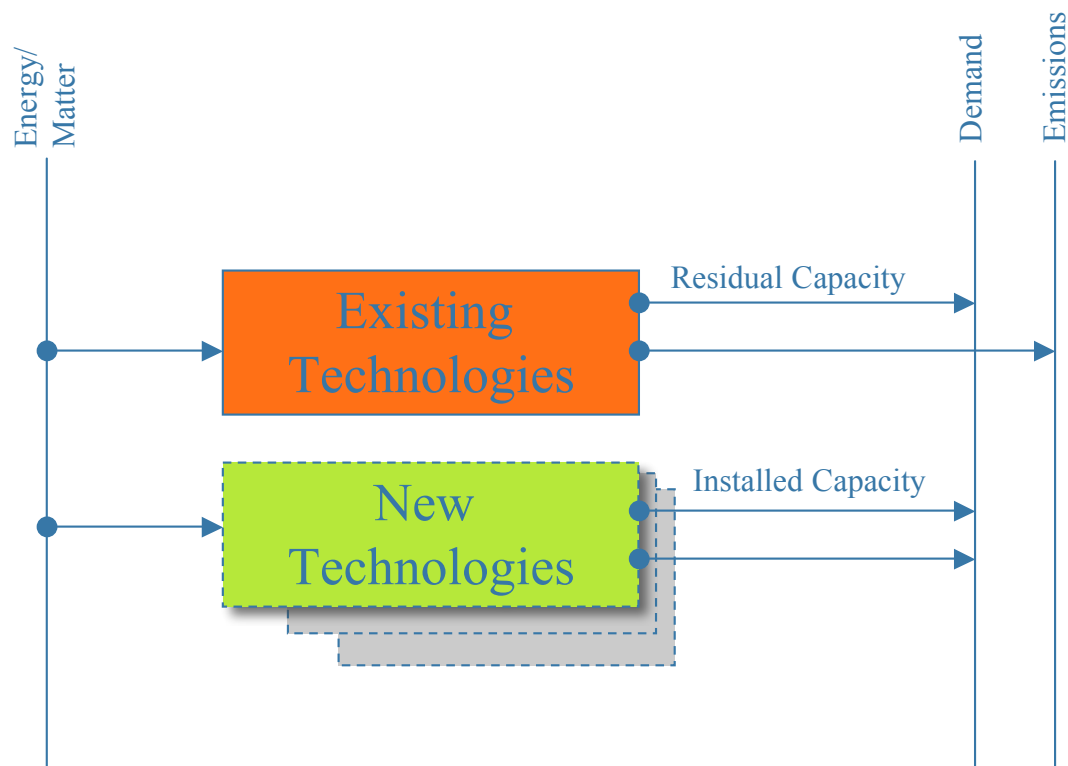

...RES Steel Industry

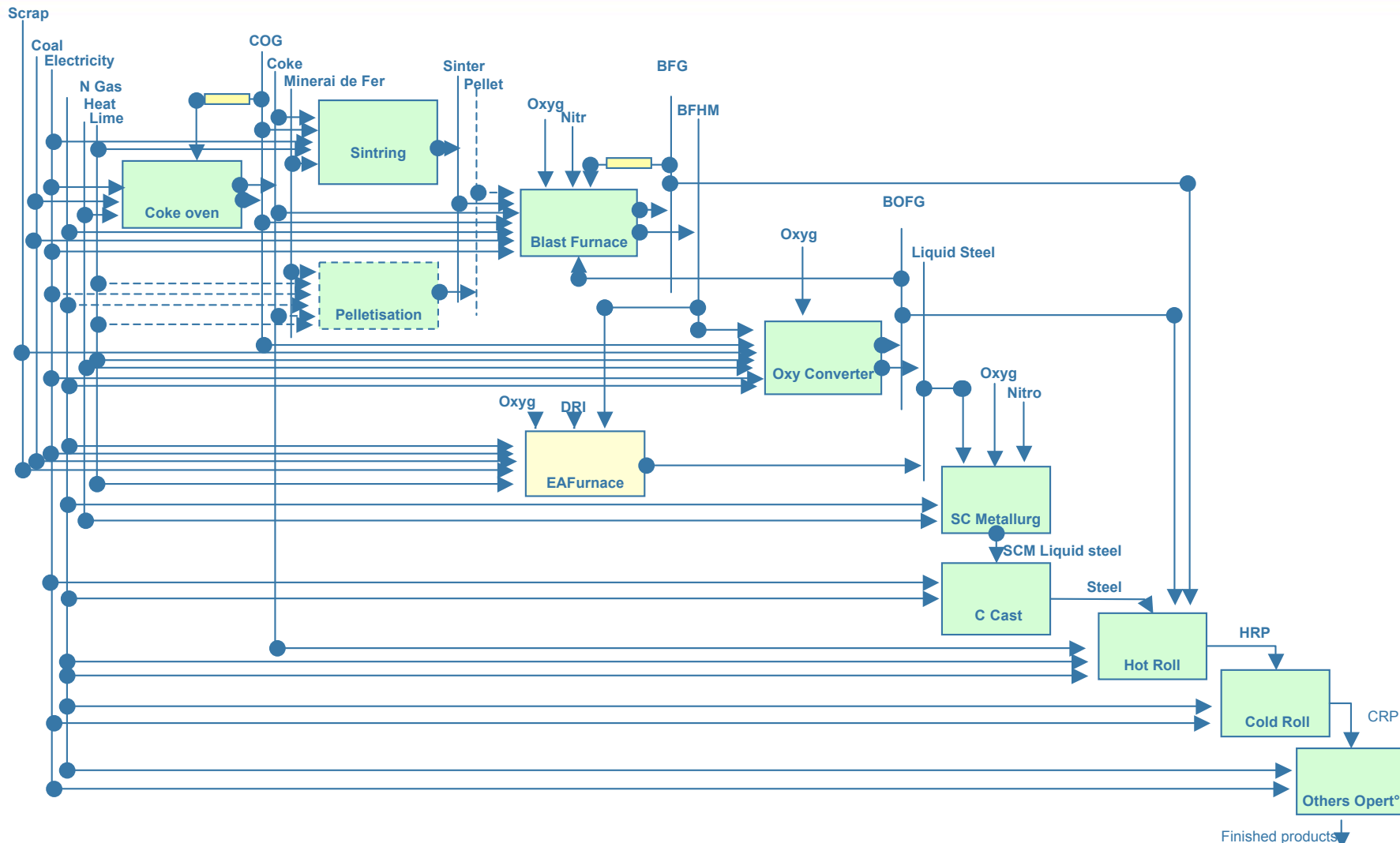

...RES Paper Industry

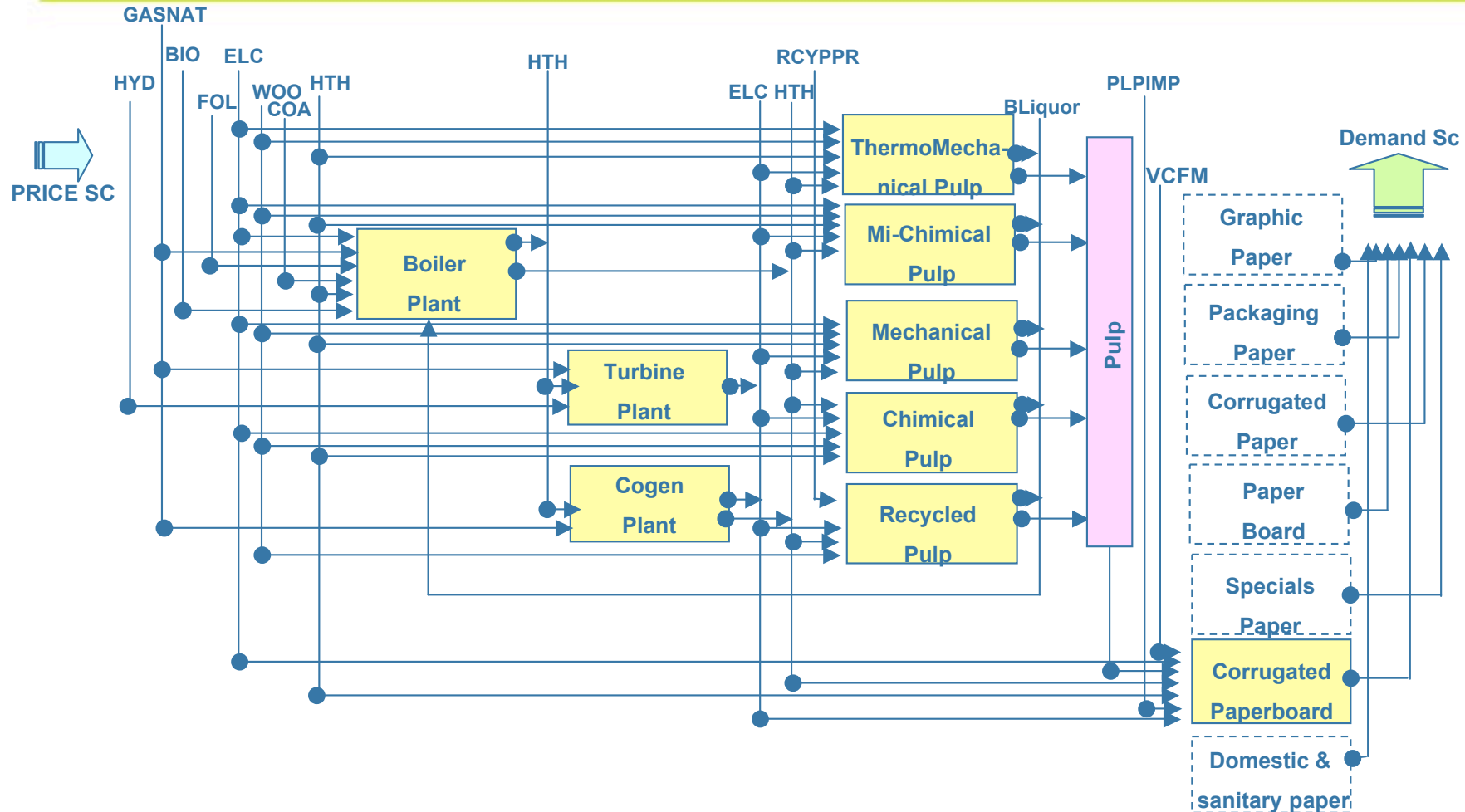

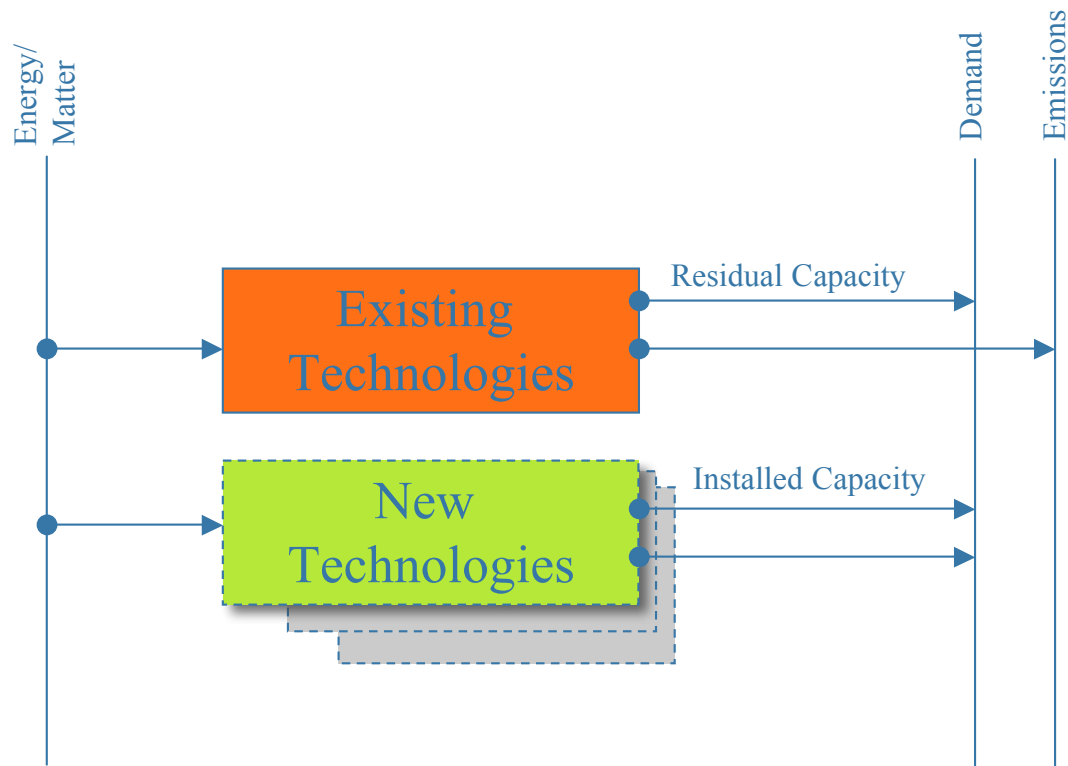

...Steel Routes Production

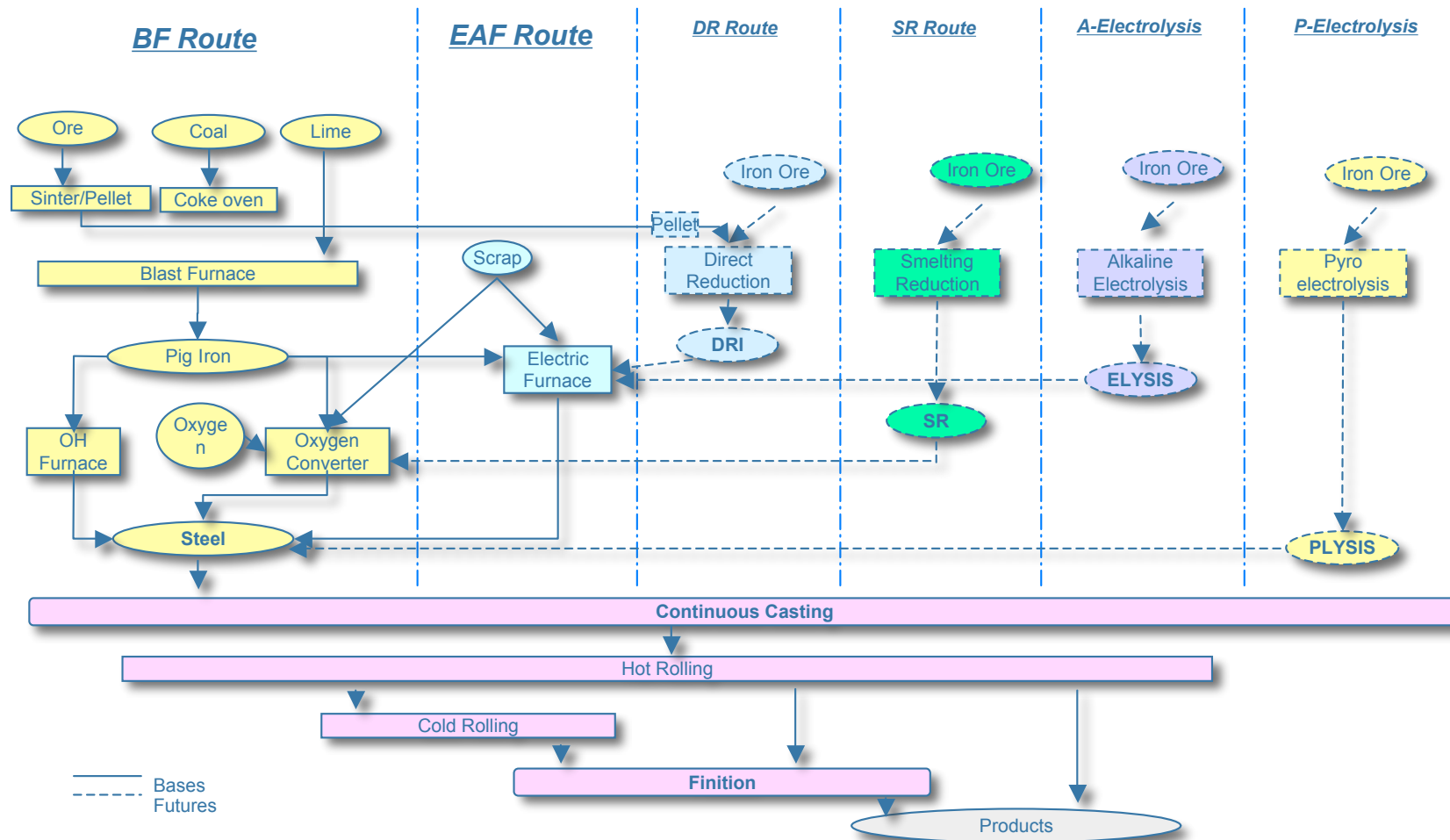

... Paper Industry Available Technologies

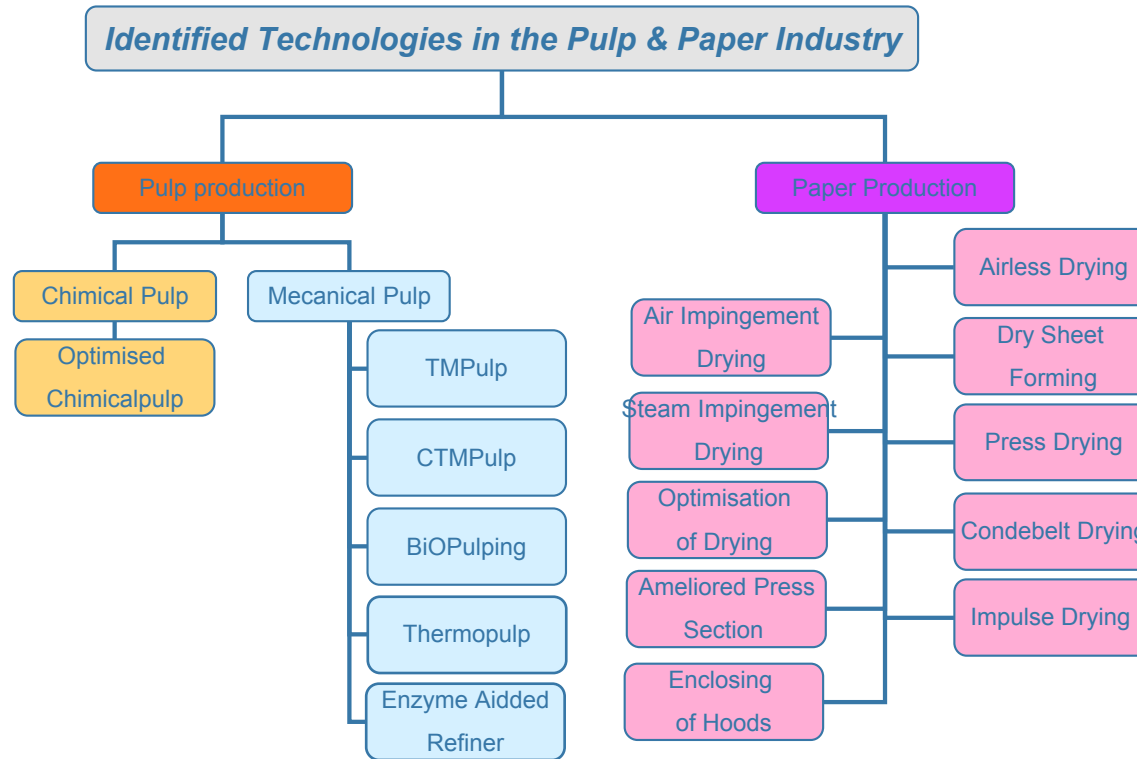

...Scenarios

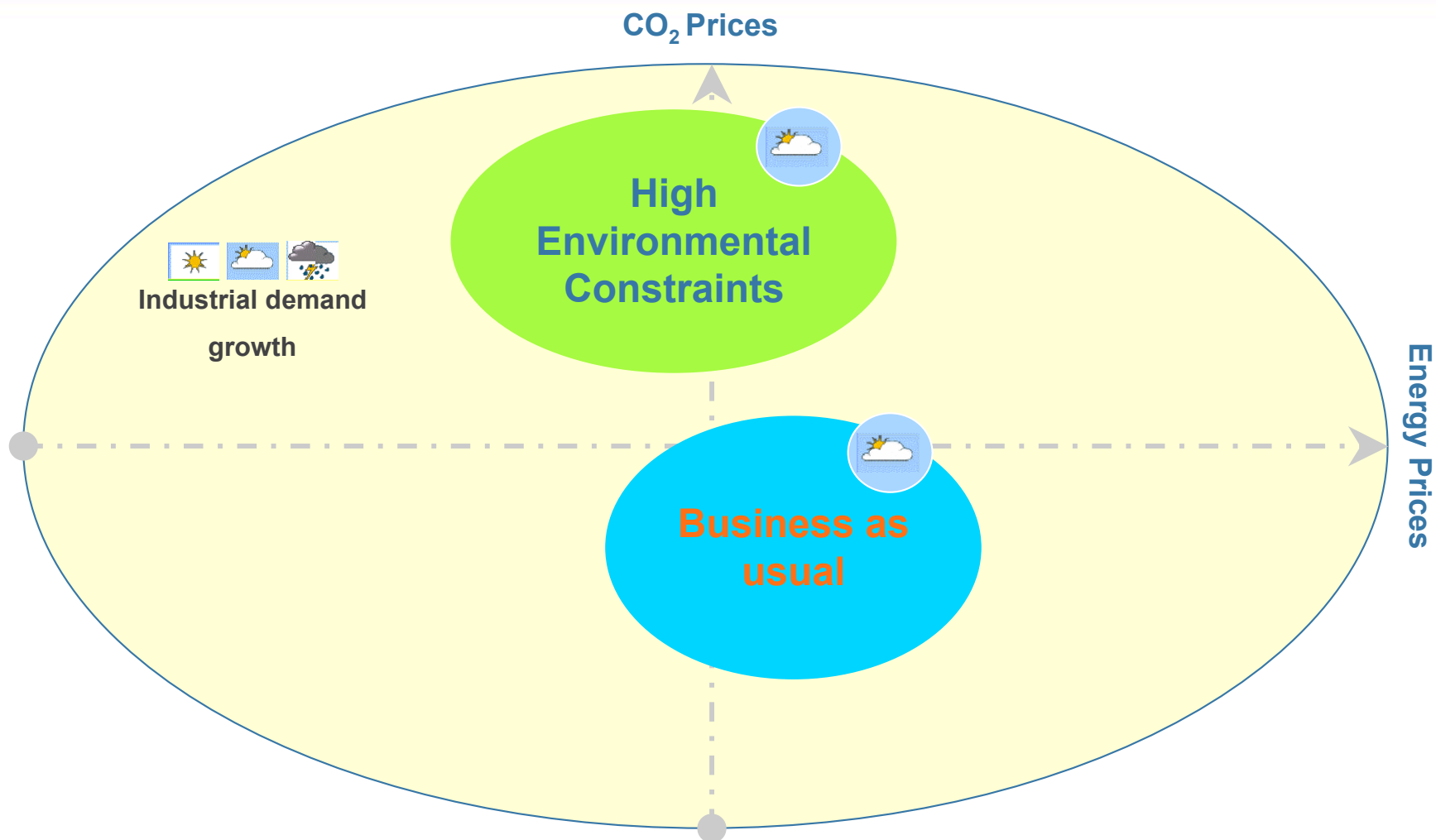

...Demand Scenario



CTP Demand Scenario by product (%)

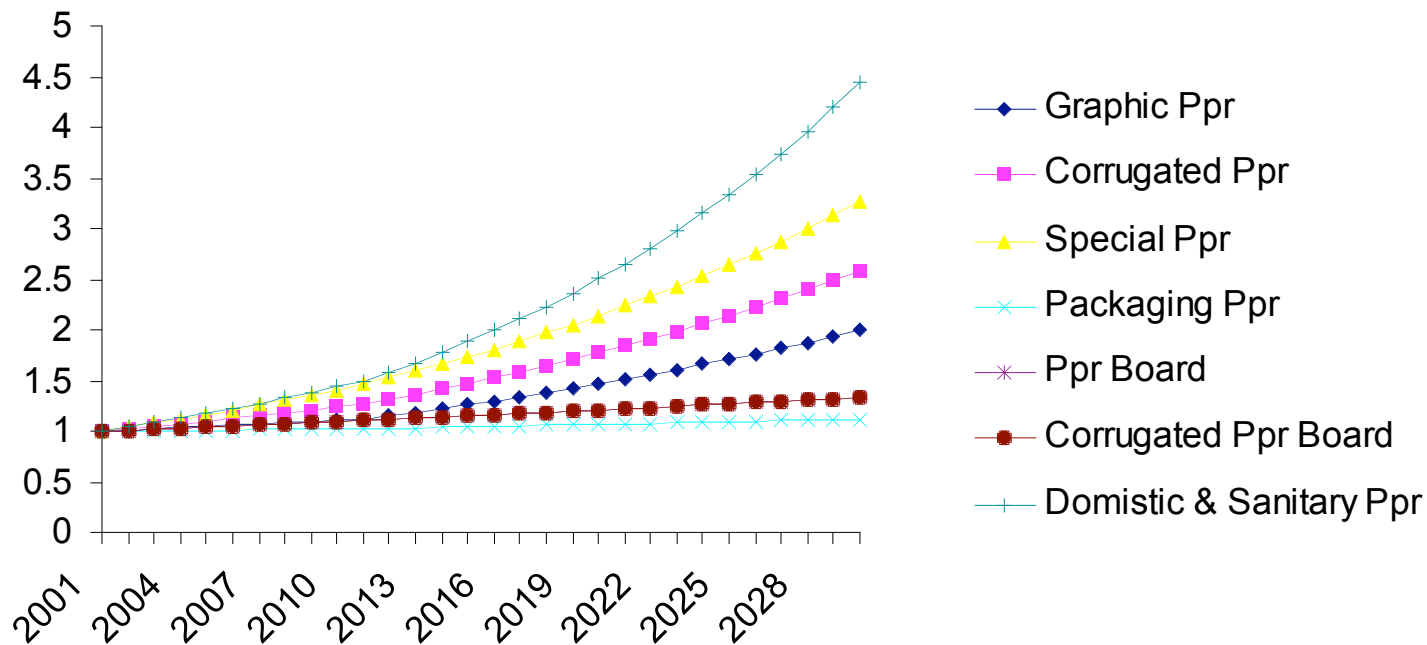

In the Iron & Steel industry the demand scenario is a final steel product scenario, with stability until 2015 and a 1%/year growth up to 2030.

...Scenarios

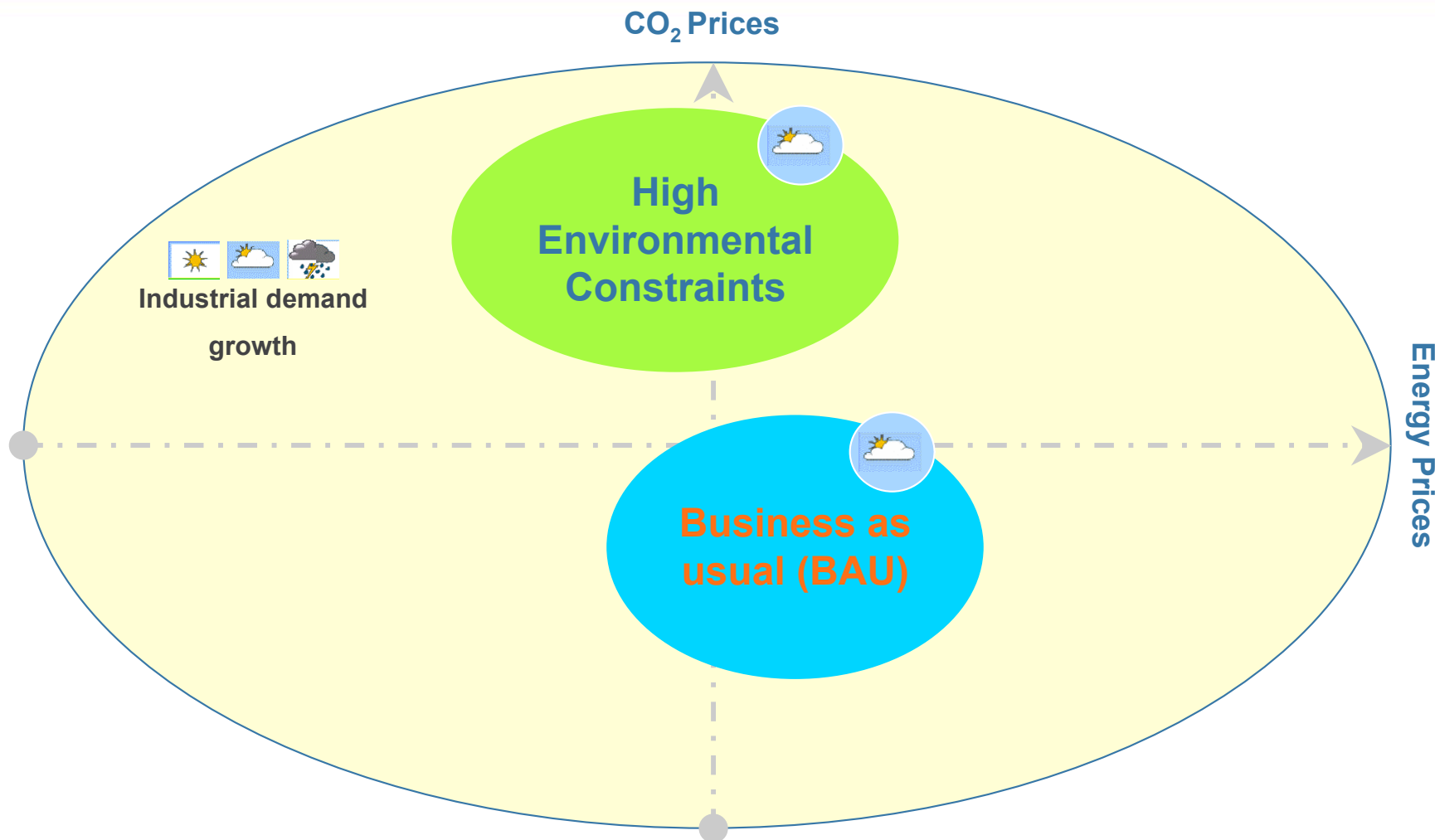

...Price Scenario BAU



Demand scenario key indicators

Key Indicators	1990	2001	2010	2030	2050	Growth (%/an)		
						1990/10	2010/30	2030/50
Population (Billions)	5.2	6.1	6.8	8.1	8.9	1.3%	0.9%	0.5%
GDP (MEURO)	29	42	59	105 930	164 090	3.5%	2.9%	2.2%
GDP per capita (EURO)	880	224	524 8	13 107	18 513	2.2%	2.0%	1.7%
	5 697	6 907	764					

Energy prices BAU SC (€/MWh)

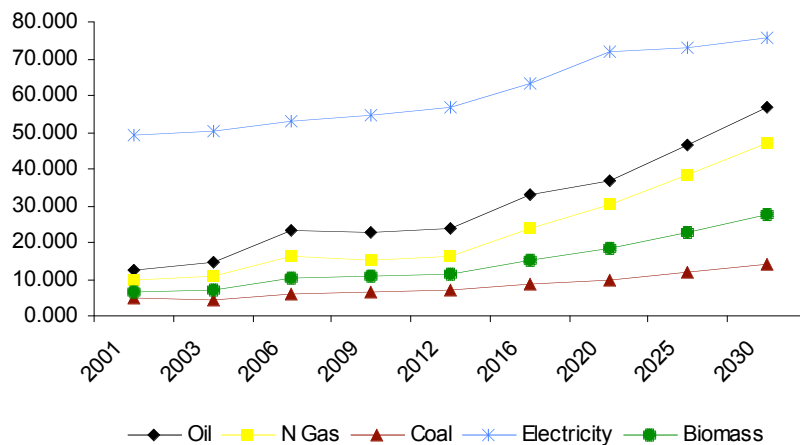

CO2 Tax in the BAU Scenario (Euro/t)

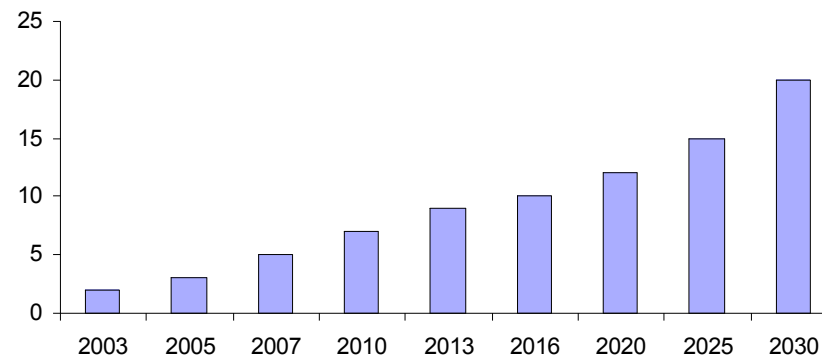

...Scenarios

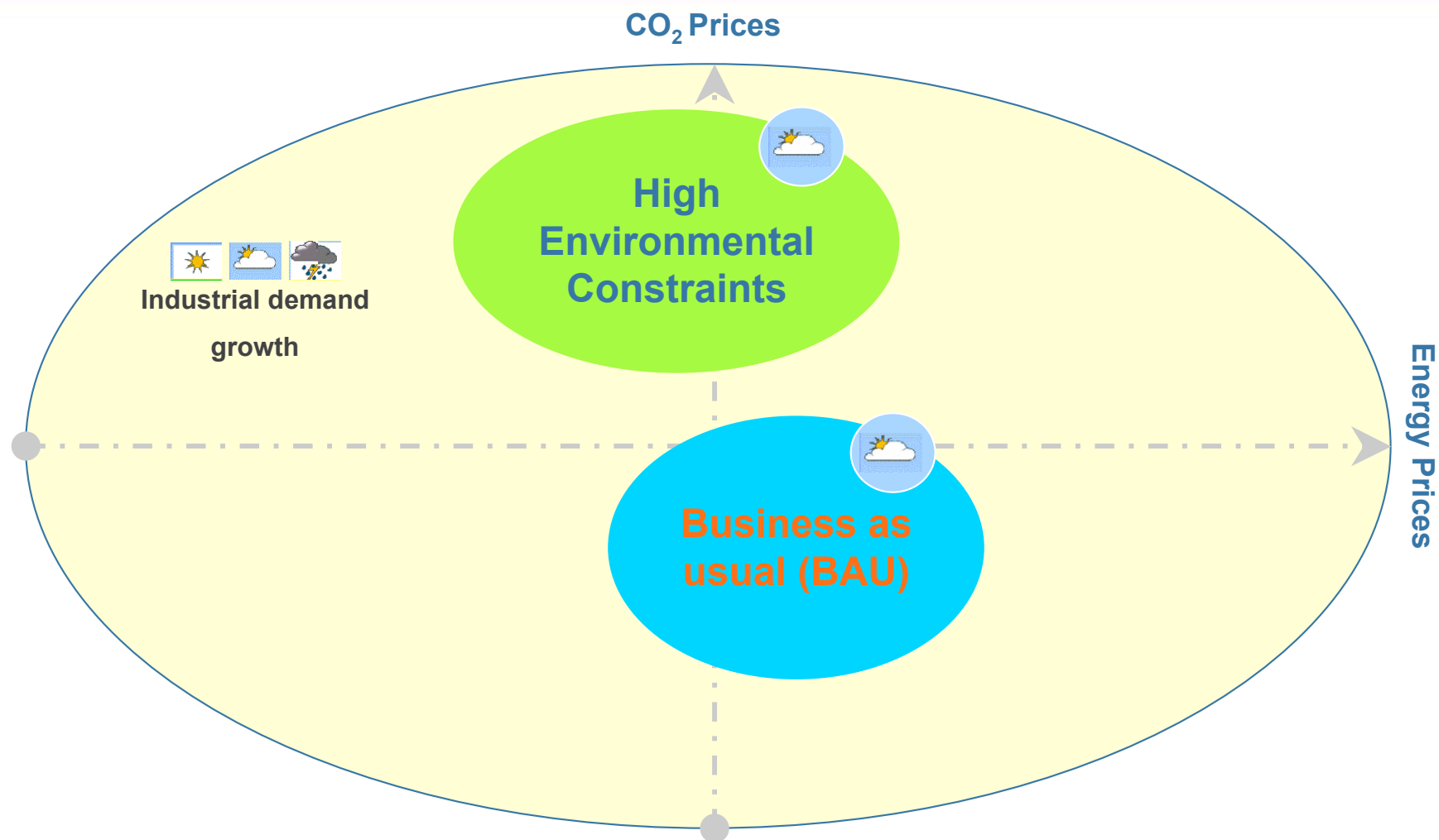

...Price Scenario High Env Const



Demand scenario key indicators

Key Indicators	1990	2001	2010	2030	2050	Growth (%/an)		
						1990/10	2010/30	2030/50
Population (Billions)	5.2	6.1	6.8	8.1	8.9	1.3%	0.9%	0.5%
GDP (MEURO)	29	42	59	105 930	164 090	3.5%	2.9%	2.2%
GDP per capita (EURO)	880	224	524 8	13 107	18 513	2.2%	2.0%	1.7%
	5 697	6 907	764					

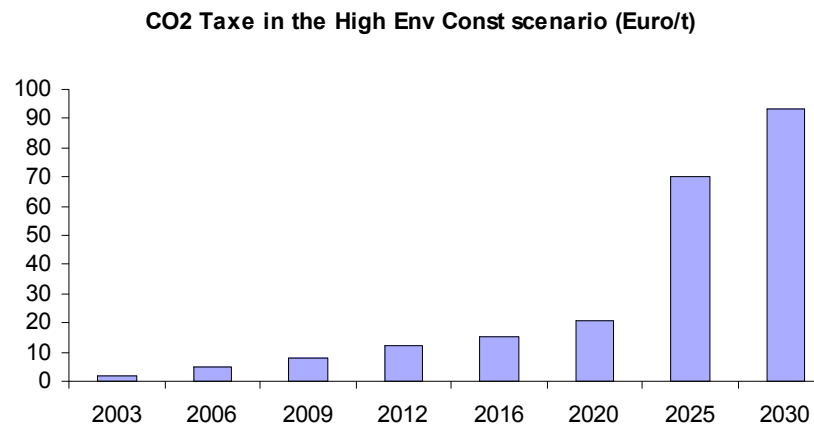
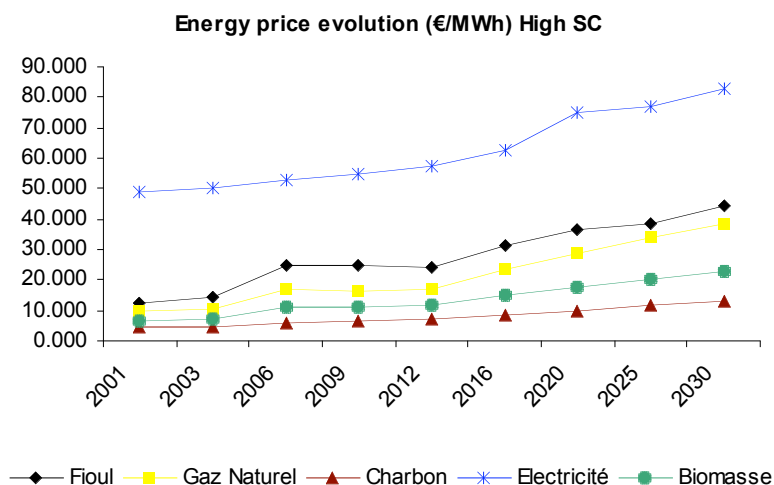

...Paper production by technology in the BAU Sc

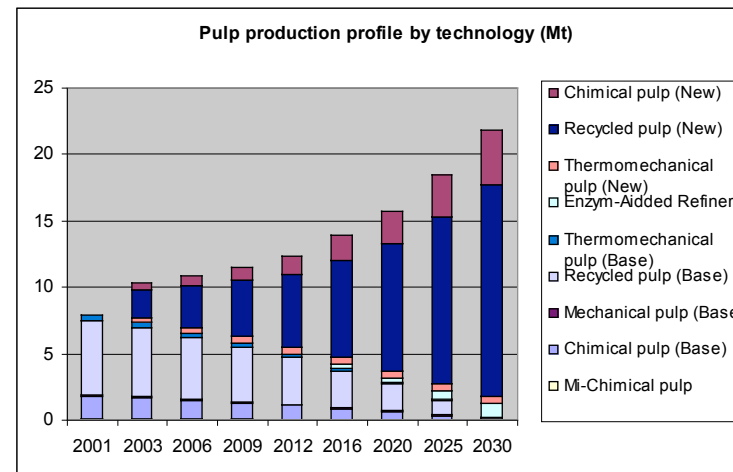
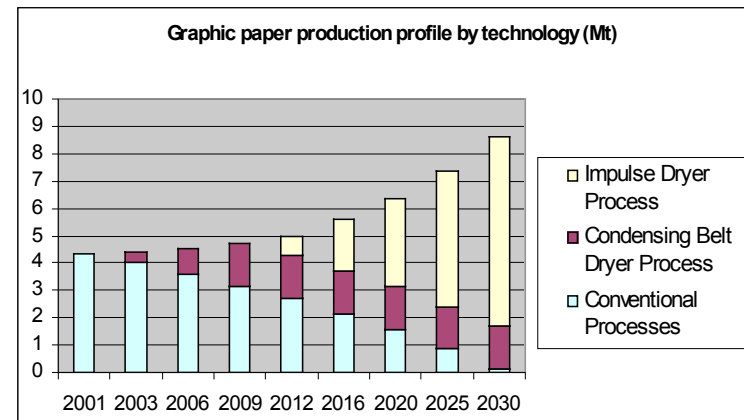
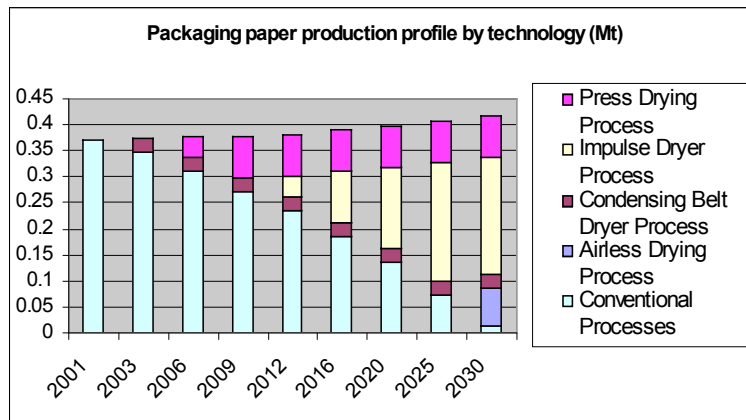

... Steel production by technology

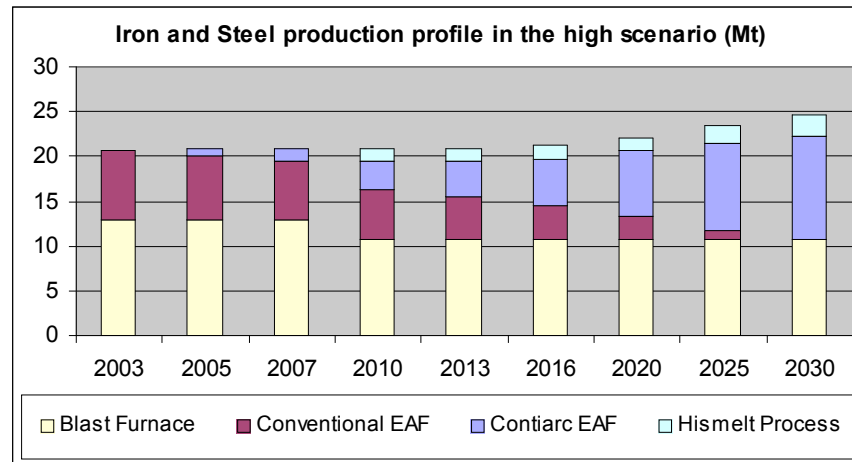
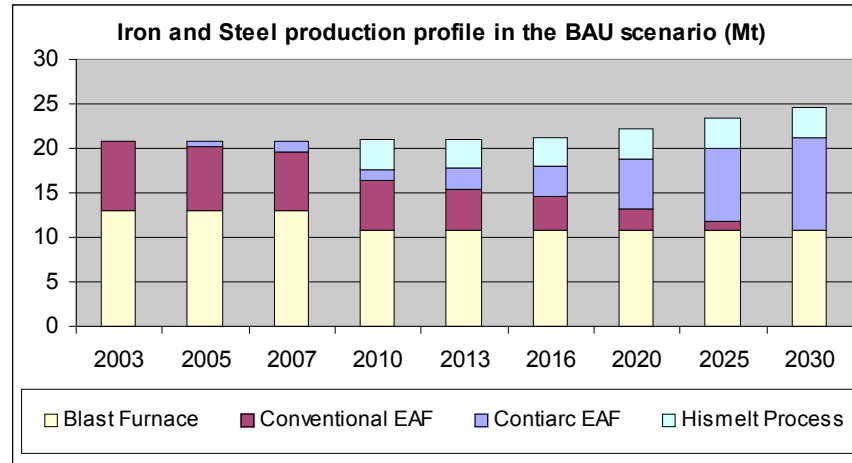

...Pulp & Paper Energy Consumption

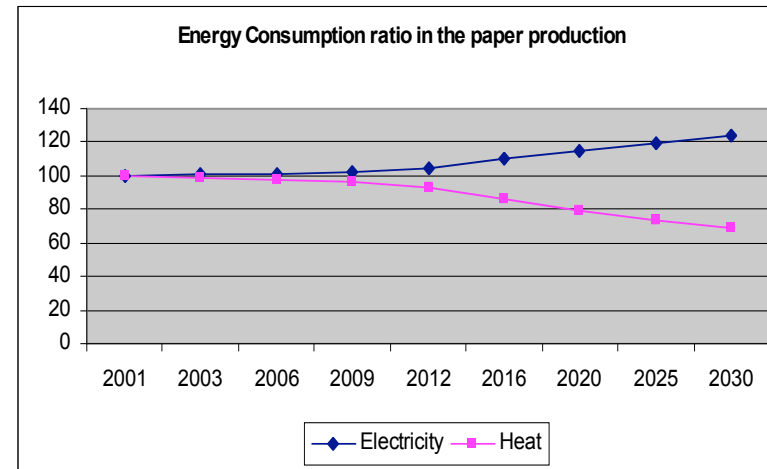
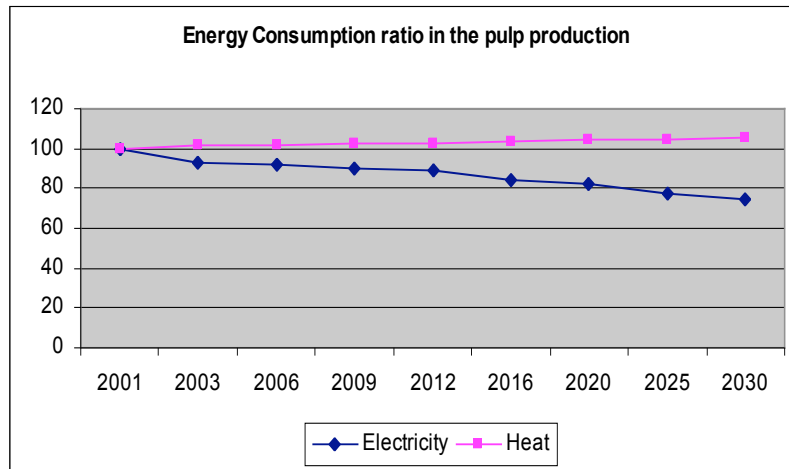
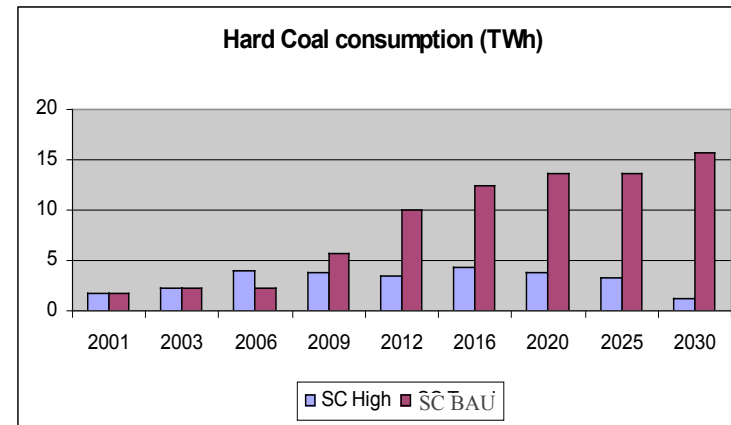
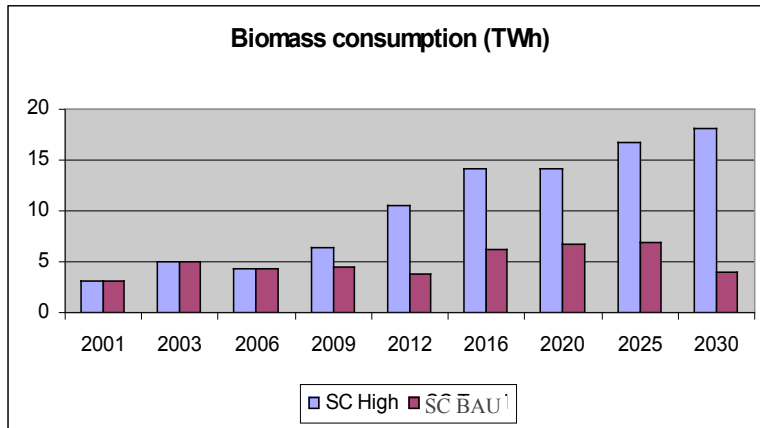

... Iron & Steel Energy Consumption

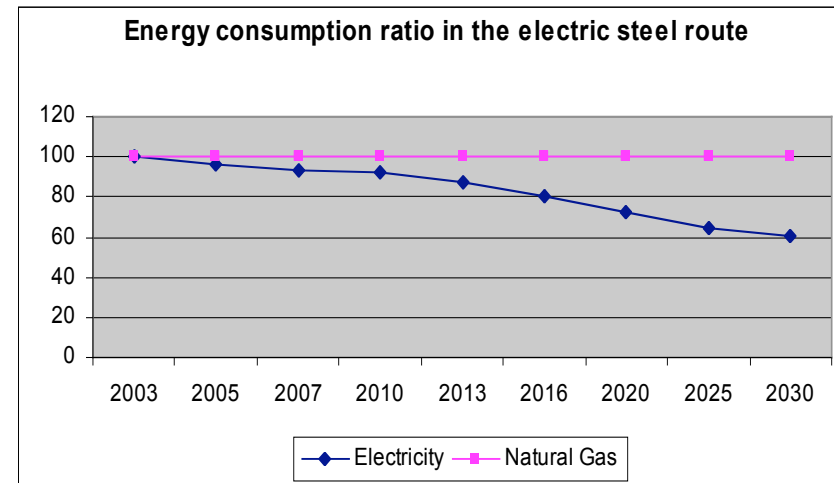
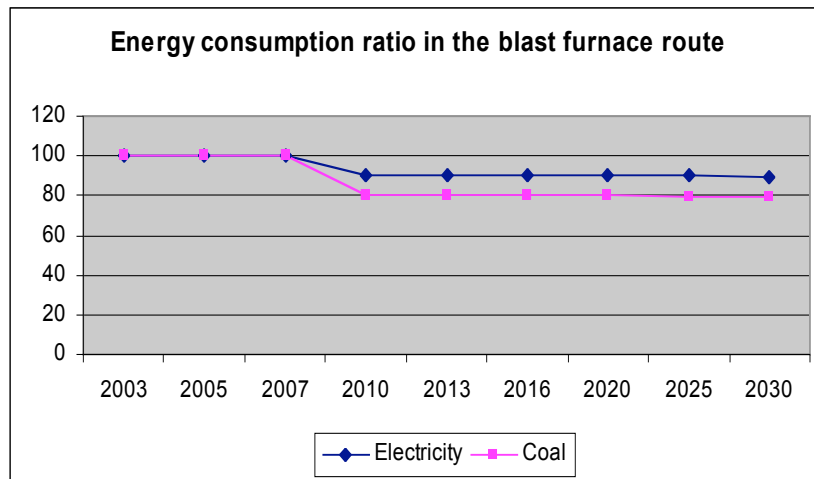
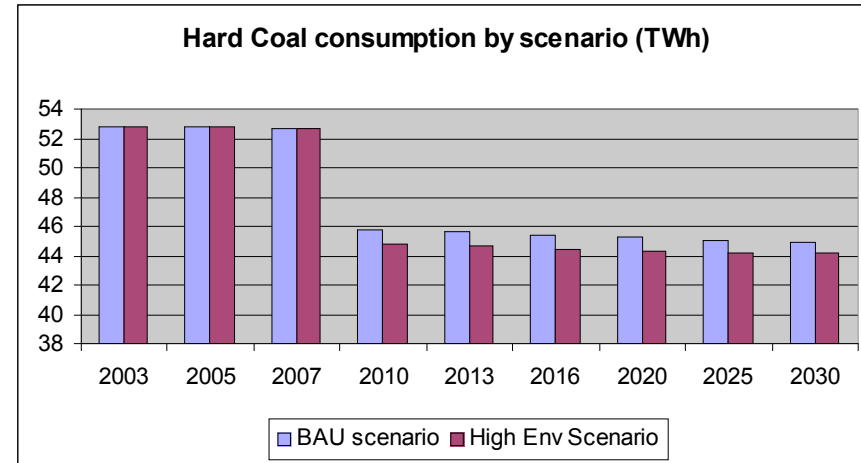
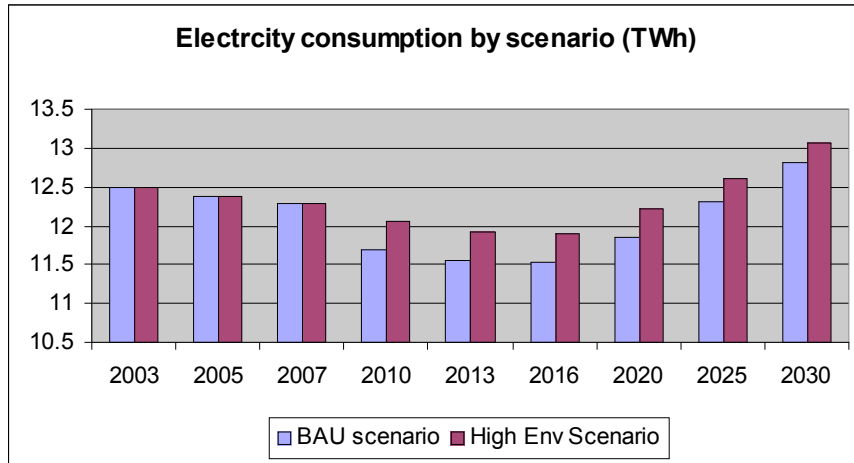

...CO2 Emissions by Industry

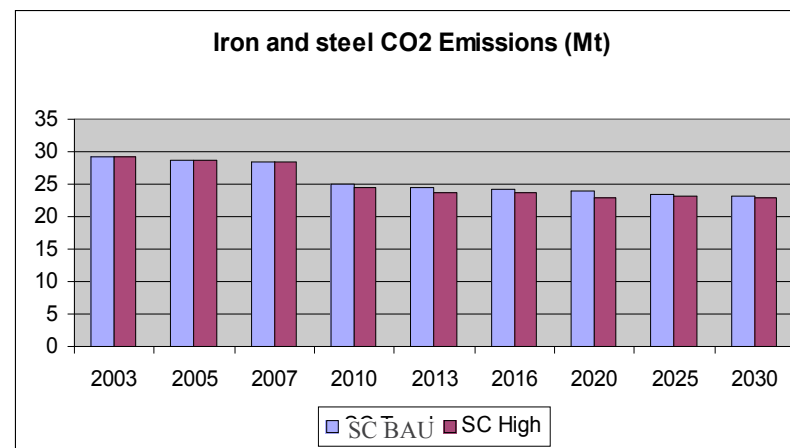
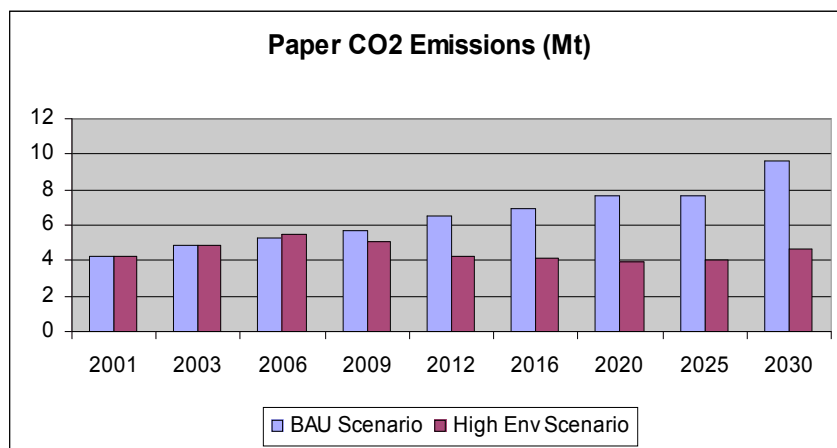

...Conclusions



The energy savings remain exist in the industry.

The results show that:

- **The emergence of the Enzyme aided refining and the new thermo-mechanical pulp process; allow electricity saving in the mechanical pulp production of about respectively 100kWh/t and 90kWh/t.**
- **The appearance of some new drying processes like the impulse dryer process in the paper production permit an increase of about 23% in the electricity consumption and 31% decrease in the heat consumption.**
- **The upraise of the Contiarc EAF in iron and steel industry allowed less electricity consumption in the electric arc furnace route of about 40%.**
- **The HISmelt process reduces both the coal and the electricity consumption by about respectively 20 %, 10% and permits less CO₂ emissions in blast oxygen furnace route.**
- **However, at 93 euro/tCO₂ in 2030, the huge investments needed for Alkaline electrolysis or Pyroelectrolysis can not be justified though such processes emit no CO₂.**
- **These two sectors do not react in the same manner in terms of this environmental constraint: the manufacturing processes in the iron & steel industry are much more influenced.**



Thanks for your attention