

Motiva

Comprehensive monitoring system –
essential tool to show the results of the
energy audit and voluntary energy
agreement programmes

Ulla Suomi

eceee Summer Study 2007 4.6-8.6.2007

Contents of the presentation

- the energy audit (EA) and voluntary agreement (VA) programmes, subsidies
- monitoring – essential part of programmes
 - how the monitoring works in field
- calculating savings
 - results
- success factors and future plans

Energy conservation agreement scheme covers approx. 60% of Finland's total energy consumption

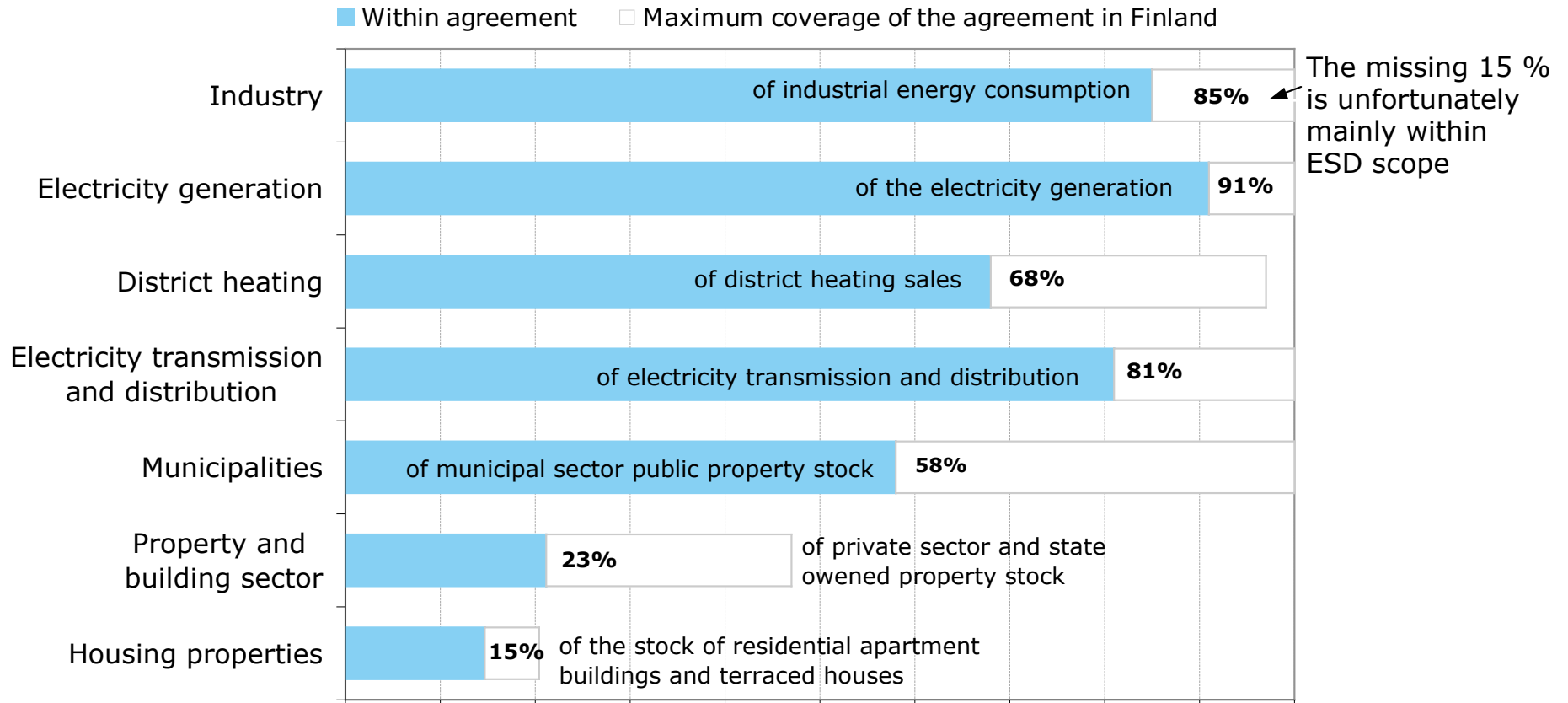

In addition:

- public transport energy conservation agreement – covers 45% of bus and coach stock and all of national railways local services, tram and the metro
- energy conservation programme for truck and van transport – covers almost 70% of actual truck and van transport
- Höylä II energy conservation programme for oil-heated properties – covers more than 15% of heating energy consumption of residential, service and agricultural buildings

Coverage of energy audits during period 1992-2005

- **Municipal sector: 54%** of building volume
 - 3 700 buildings – 62,5 million m³
- **Private services: 28%** of building volume
 - 1 600 buildings – 66,8 million m³
- **Industry: 65-70%** of total energy use
 - ~700 sites, 110 TWh (from where electricity ~33 TWh/a)
- **Power plants: 25%** of electricity generation
 - ~40 during the years 1998-2005
- **DH plants: 70%** of delivered heat
 - 10% (~30) within the EAP during the years 1998-2005, 60% without the subsidies

Cumulative subsidies for energy audits and investments for energy conservation measures granted by MTI to enterprises/communities participating energy conservation agreements

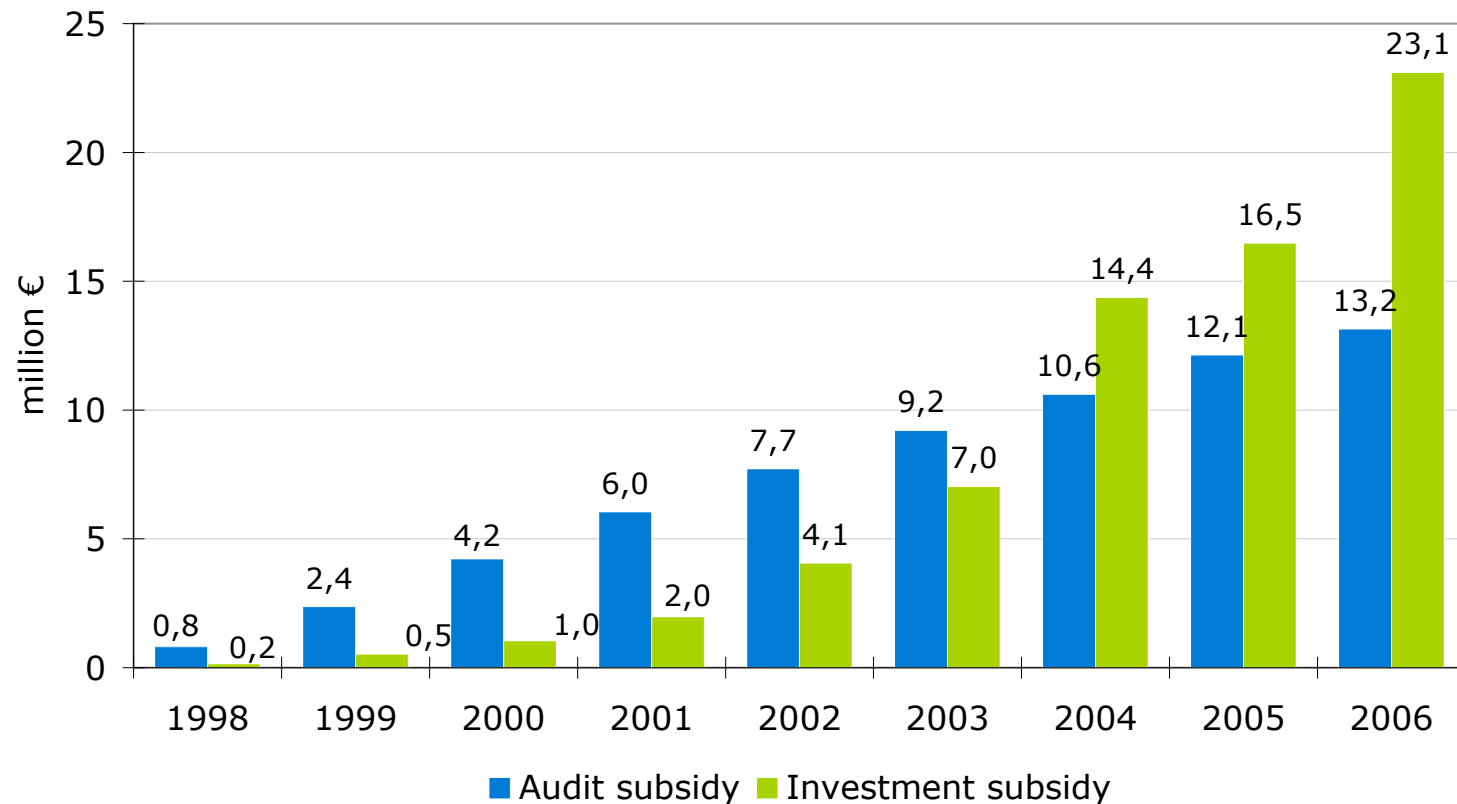

- Of the total audit subsidies granted by MTI 1998-2006 (13.2 million euros) the share of industry is 60%, municipal sector 19%, property and building sector 10%, power plant sector 8% and district heating sector 3%.
- Of the total investment subsidies granted by MTI between 1998-2006 for energy conservation measures (23.1 million euros) the share of industry is 62%, power plant sector 27%, municipal sector 6%, district heating sector 4% and property and building sector 1%.

Different levels of monitoring

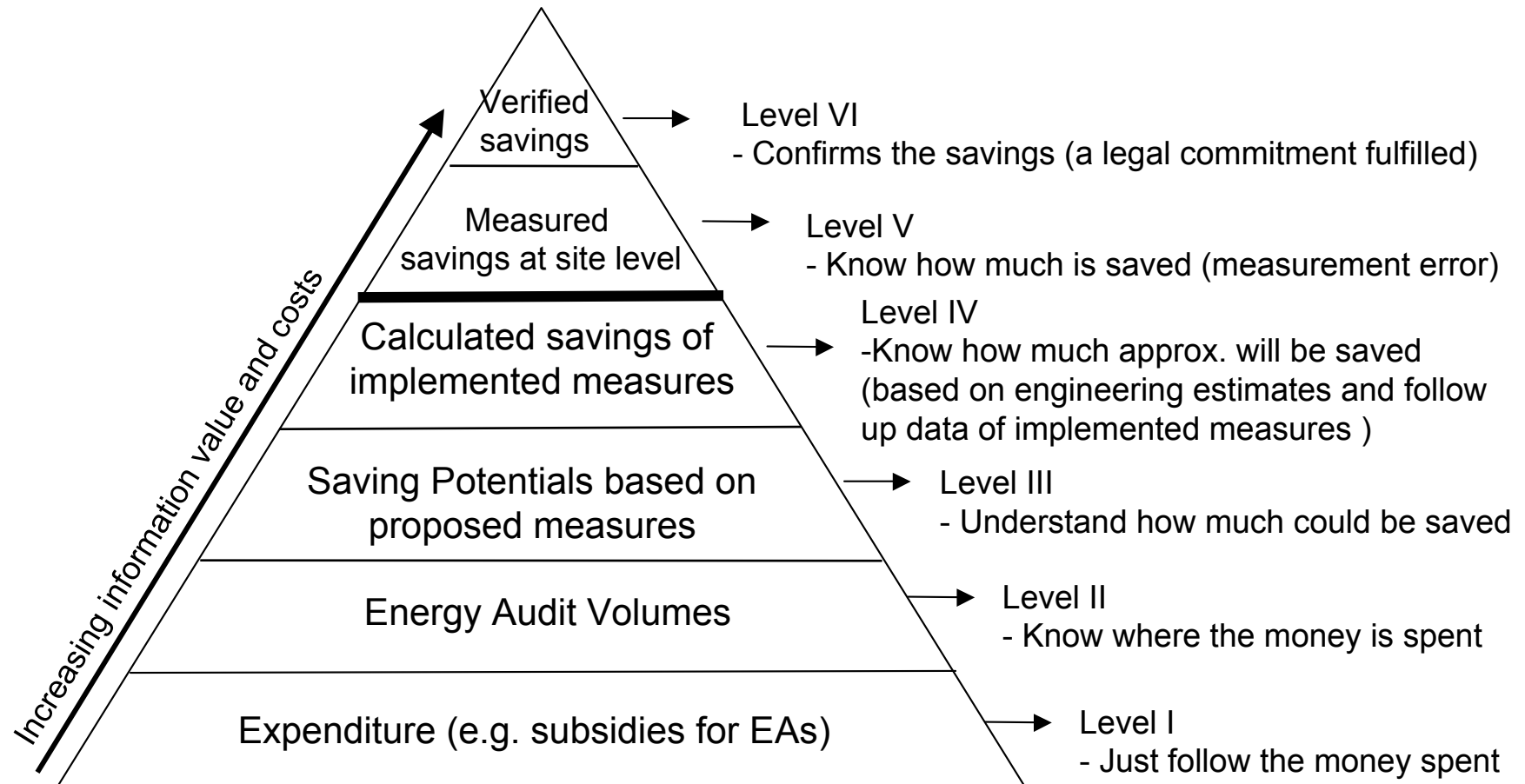

Monitoring – what should be considered when a system is planned

- what kind of data that should be collected to compile the needed information
- what is the target group for the data (e.g. ministries, feed back for clients, auditors, media etc.)
- level of ambition should be decided upon as early as possible when planning the programme
- the monitoring system should be designed at the same time as the programme
- monitoring system should cope with an expansion of the programme
- if follow-up data is needed, how to collect it?

How is the data collection organised in Finland?

ENERGY AUDITS

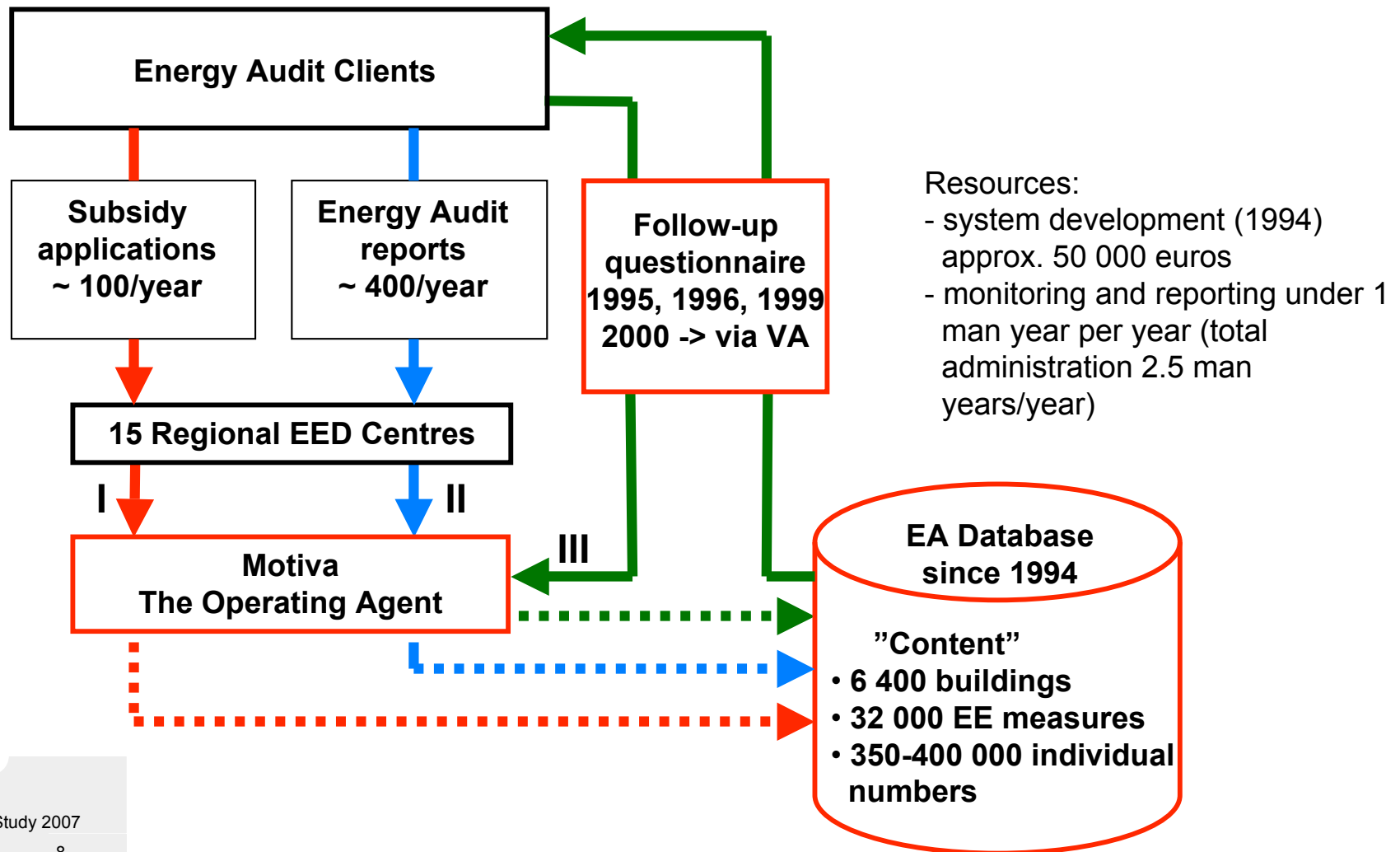

"Table 2" – data filed from measures

ENERGY AUDITS

TABLE 2
SUMMARY OF THE PROPOSED MEASURES

MEASURE	TOTAL SAVING €/a	ROI a	INVESTMENT €	CO2 reduction t/a	ENERGY SAVING						WATER SAVING		STATUS OF IMPLEMENTATION		
					HEAT			ELECTRICITY			water m³/a	costs €/a			
					energy	costs		energy	costs						
					MWh/a	energy €/a	power €/a	MWh/a	energy €/a	power €/a					
1 Description of measure	0	0,0	0	0	0	0	0	0	0	0	0	0	0	0	DONE DECIDED CONS. NO
2 Description of measure	0	0,0	0	0	0	0	0	0	0	0	0	0	0		
3 Description of measure	0	0,0	0	0	0	0	0	0	0	0	0	0	0		
. . Normally approx. 4...10 measures/audit															
TOTAL	0	0,0	0	0	0	0	0	0	0	0	0	0	0	0	

How is the data collection organised in Finland?

VOLUNTARY AGREEMENTS

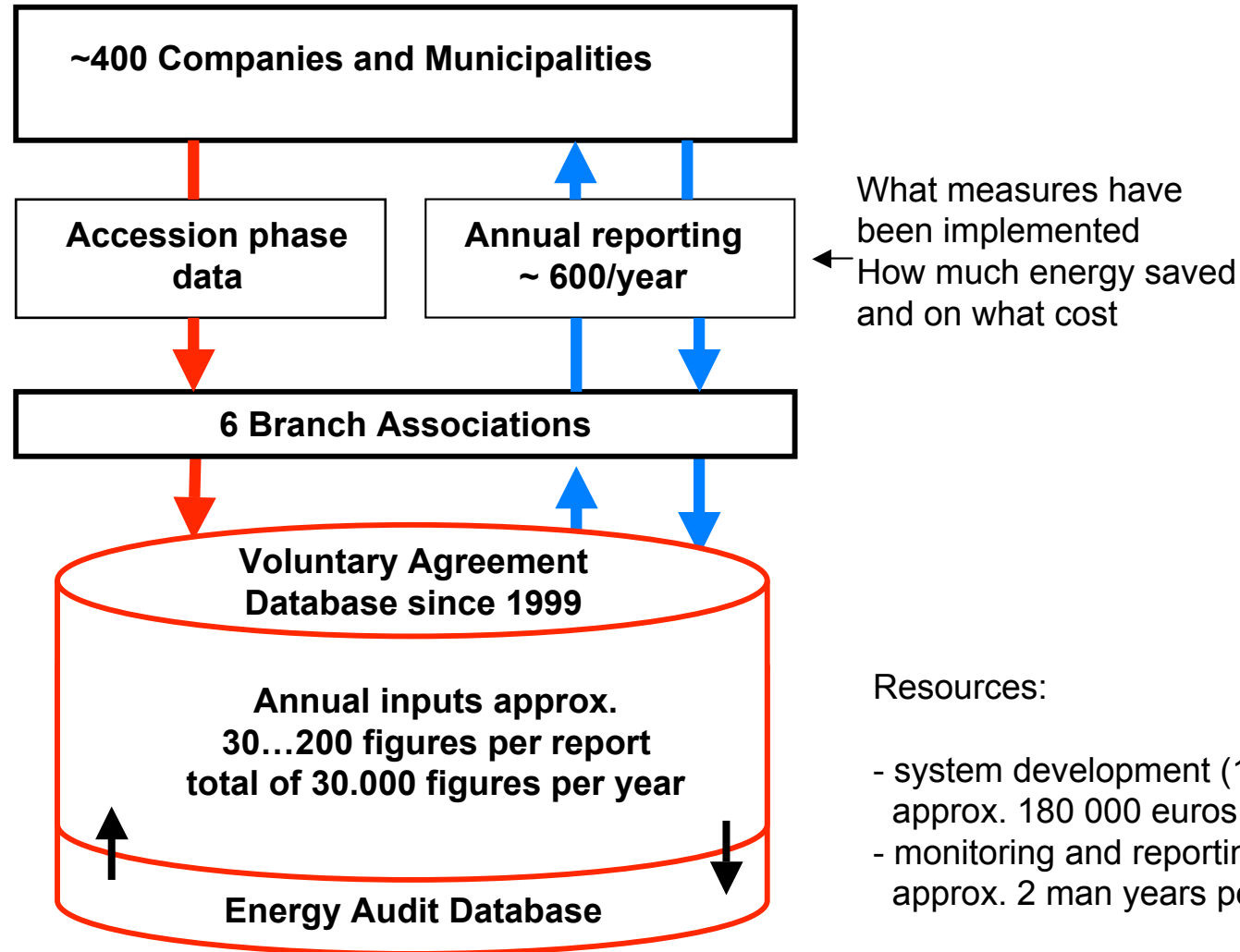

Calculating savings from Energy Audits

The MOTICOP Database

6 300 buildings divided into 31 bldg types
 32 000 measures, divided into 29 categories
 3 main sectors, industry in 8 sub-sectors

All submitted EA Reports

1992-1999

2000-2005

EA Report submitted to Motiva

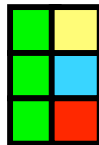

Measures proposed to the client (EA Report, ROI < 10a)



Engineer's calculations on savings from individual measures

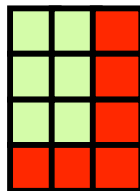

The Saving Potential

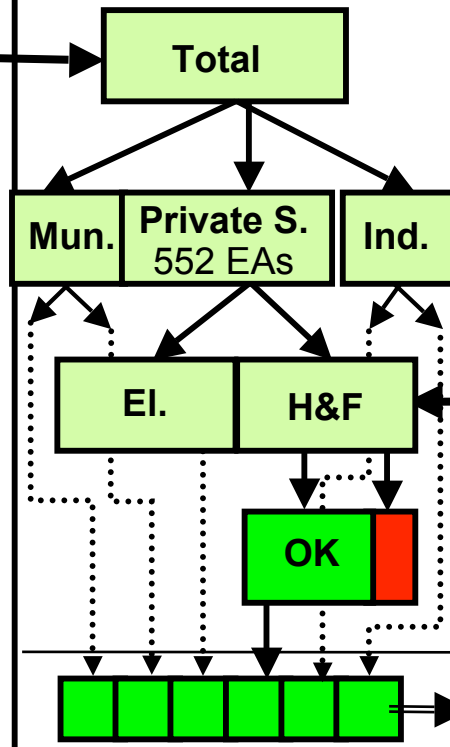

Voluntary Agreements Follow up Data - Implementation rate

Private services
 386 EA reports,
 3100 measures
 Heat & fuels

All	Done	43 %
All	Decided	29 %
1/3 *	Maybe	19 %
	No	8 %

* 5 % in industry

Calculated savings

~ 1 TWh (2005)
 (does not include process industry)

Calculating savings from Voluntary Agreements

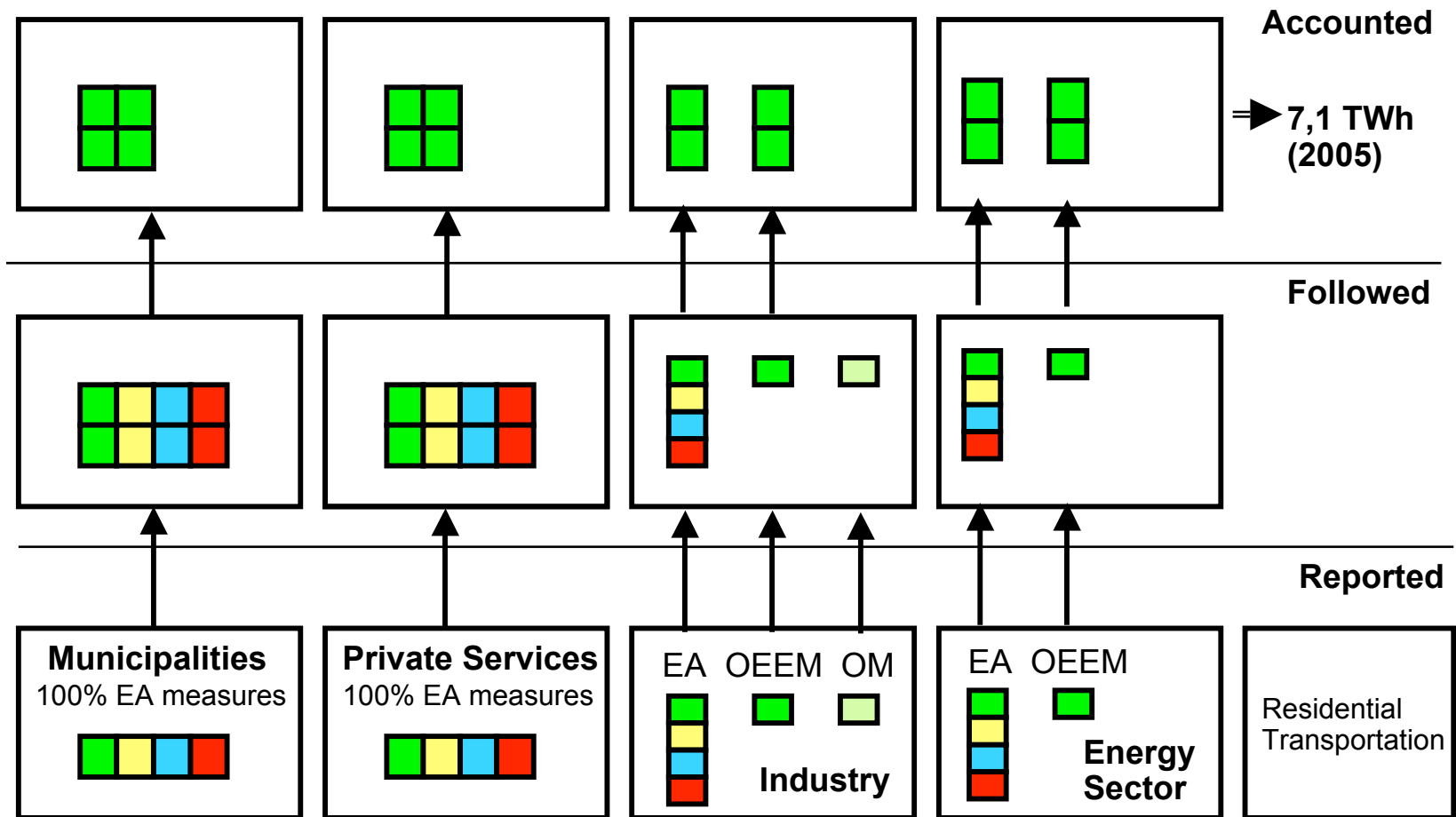

EA = EA measure
 OEEM = Other Energy Efficiency Measure
 OM = Other Measure (saves energy but is not an EE investment)

Avoiding double-counting within the three instrument package

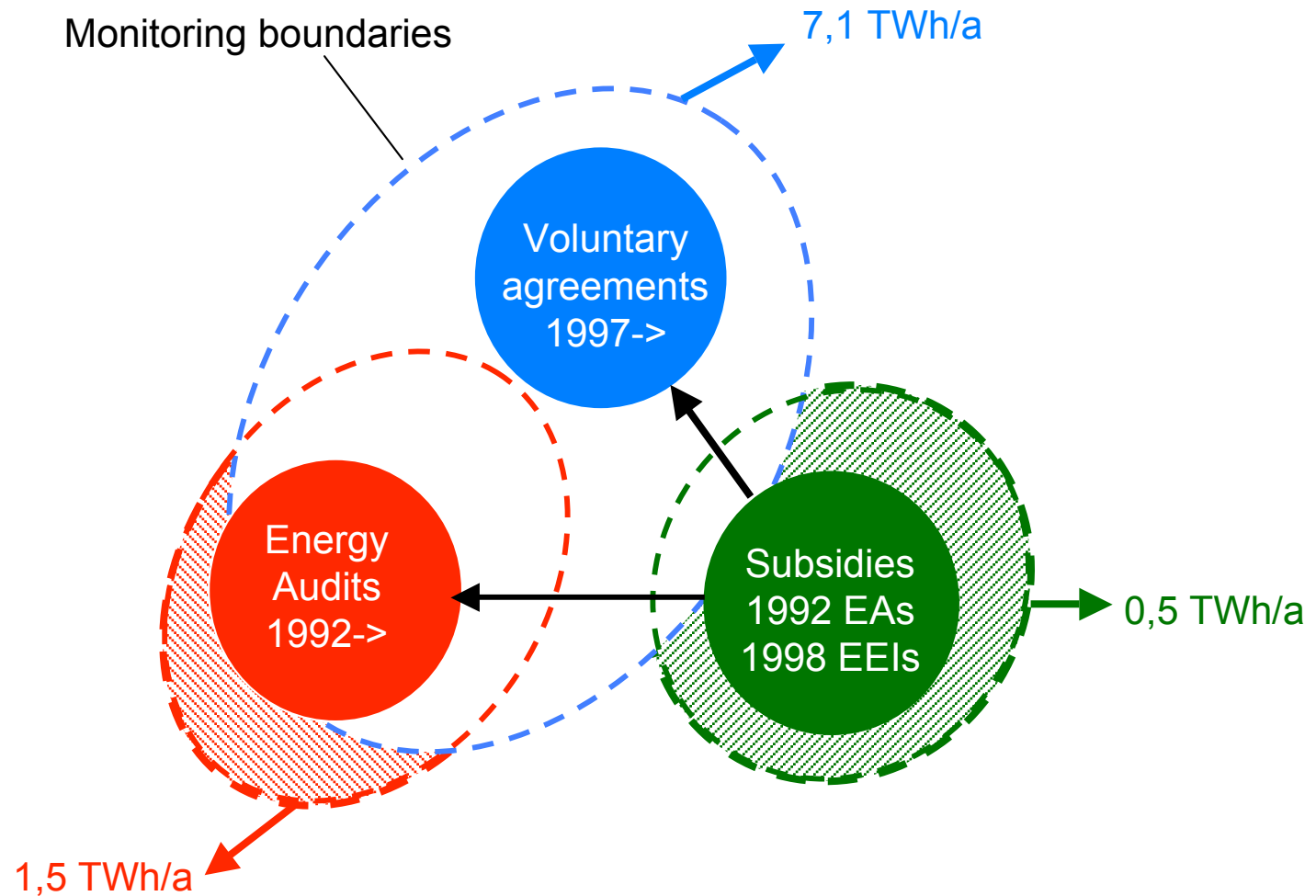

Total effect approx. 7,5 TWh/a in 2005 (not 9,1 TWh/a), preliminary

Energy saving impact of conservation measures reported as implemented by industrial, energy, municipal and property and building sectors in years 1998-2005

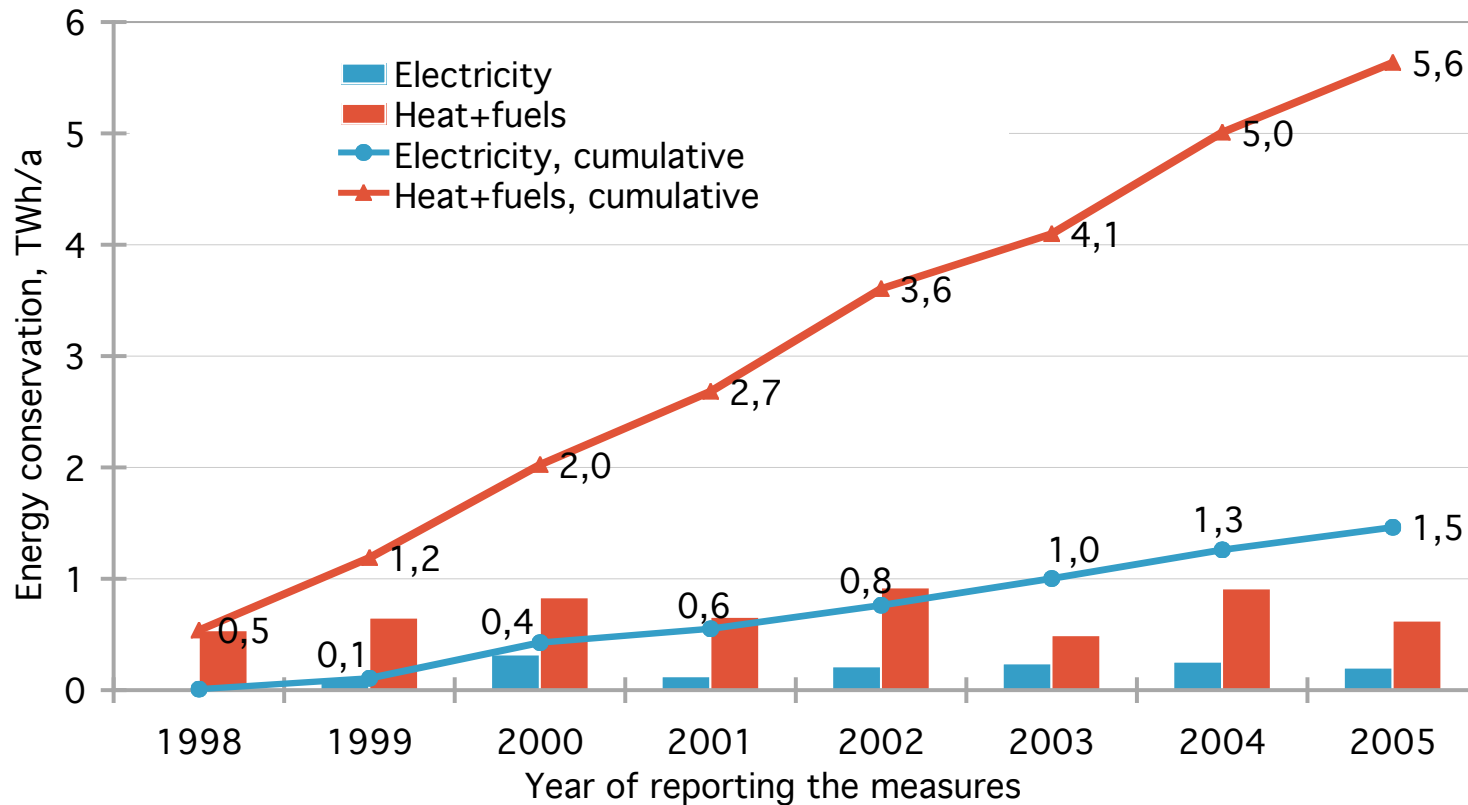

- Of the total energy conservation impact (7.1 TWh/a) the share of industry is 82% and power plant sector approx. 14%.
 - Over 310 million euros investments to carry out these measures
 - Cost savings approx. 135 million euros per year
- Share of electricity of the total energy savings per year around 20%
- Carbon dioxide emissions reduced over 2 million tonnes per year
- About 2% of Finland's total energy consumption

Energy savings by energy audits

- **Service sectors and industry***
 - Annual savings 1 TWh** and 30 M€ in 2005
 - Cumulative savings 8,5 TWh and 270 M€ (1992-2005)
- **Average realised savings in the municipal sector service buildings**
 - 9 % in heat and fuels
 - 5½ % in electricity
- **Average realised savings in the private service sector buildings**
 - 12 % in heat and fuels
 - 4 % in electricity
- **Average realised savings in industry***
 - 6...9 % in heat and fuels
 - 3...5 % in electricity

* Process industry not included

**Lifetime for savings in these calculations 6 years (ESD needs are under consideration)

The Success Factors

- **Good results**

- Well functioning monitoring systems for programmes in key position to maintain the continuous commitment
- EA broad acceptance by both the clients and the the auditors
- VA comprehensive yearly reporting by companies/communities
- According the expert evaluation of the VA scheme its has worked well in terms of coverage, achieving its objectives and according to views expressed by agreement parties
- According the evaluation (IEE/AIE-EE) of the EA programme in Finland has been a generally successful programmes and no major failure factors were identified

- **Long-term top-level commitment**

- Energy audits mentioned in every energy policy paper since 1992 - voluntary agreements since they were launched 1997
- Energy audit subsidies available since 1992
- Investment subsidies for EE measures since 1998
- Adequate resources for programme administration

- **And...because of the success, new period 2008–2016 of VA's is in drafting phase**

- New web based monitoring system will be developed 2008-2009

... some comments

- **Free rider effect not monitored**
 - vital aim is that saving measures are actually carried out
- **On-site “field” conditions are far from laboratory conditions**
 - we need to be realistic, what can be measured and what not
 - also realism is needed what data can be gathered e.g. in yearly reporting
- **Small savings cannot be identified from the total consumption**
 - sometimes not worth while measuring at all – just adjust the set point
- **The end-user might not be interested to spend money on M&V**
 - who will pay for the M&V if more accurate data is needed?
- **How to get more reliable data with reasonable costs?**
- **Keep it simple!**

Motiva

Energiankäytön uusi suunta

Thank You!

www.motiva.fi

Proposed energy saving measures in energy audits during the period 1992–2003

ENERGY AUDITS

Category of measure	Measures pcs.	Savings 1000 EUR	Invest. 1000 EUR	ROI a
1 Heating system	284	1 006	3 438	3,4
1.1 Heat production, district heating basic rates	900	2 119	2 553	1,2
1.2 Reduction of indoor temperature	1 617	1 480	2 479	1,7
1.3 Controls of the heating system	1 525	1 815	7 001	3,9
1.4 Tightness of the building envelope	171	268	1 123	4,2
1.5 Technical system insulations	200	284	581	2,0
Total of system	4 697	6 972	17 175	2,5
2 Ventilation system	446	1 781	6 415	3,6
2.1 Running hours	3 956	9 852	3 999	0,4
2.2 Reduction of air flows	682	1 911	2 795	1,5
2.3 Separation of service areas	122	369	980	2,7
2.4 Controls of the ventilation system	1 853	2 367	2 934	1,2
2.5 Heat-recovery	1 259	6 486	25 033	3,9
2.6 Night cooling ventilation	84	49	35	0,7
Total of system	8 402	22 814	42 192	1,8
3 Domestic water, Total of system	3 470	3 017	5 011	1,7
4 Electricity, Total of system	9 885	13 883	20 257	1,5
5 Cooling systems, Total of system	460	3 221	8 466	2,6
6 Construction, Total of system	484	957	3 465	3,6
7 Compressed air system, Total of system	51	226	395	1,7
8 Other energy saving measures	1 310	26 788	72 747	2,7
All proposed energy saving measures	28 759	77 879	169 708	2,2

How the data collection is organised? Starting from the field...

ENERGY AUDITS

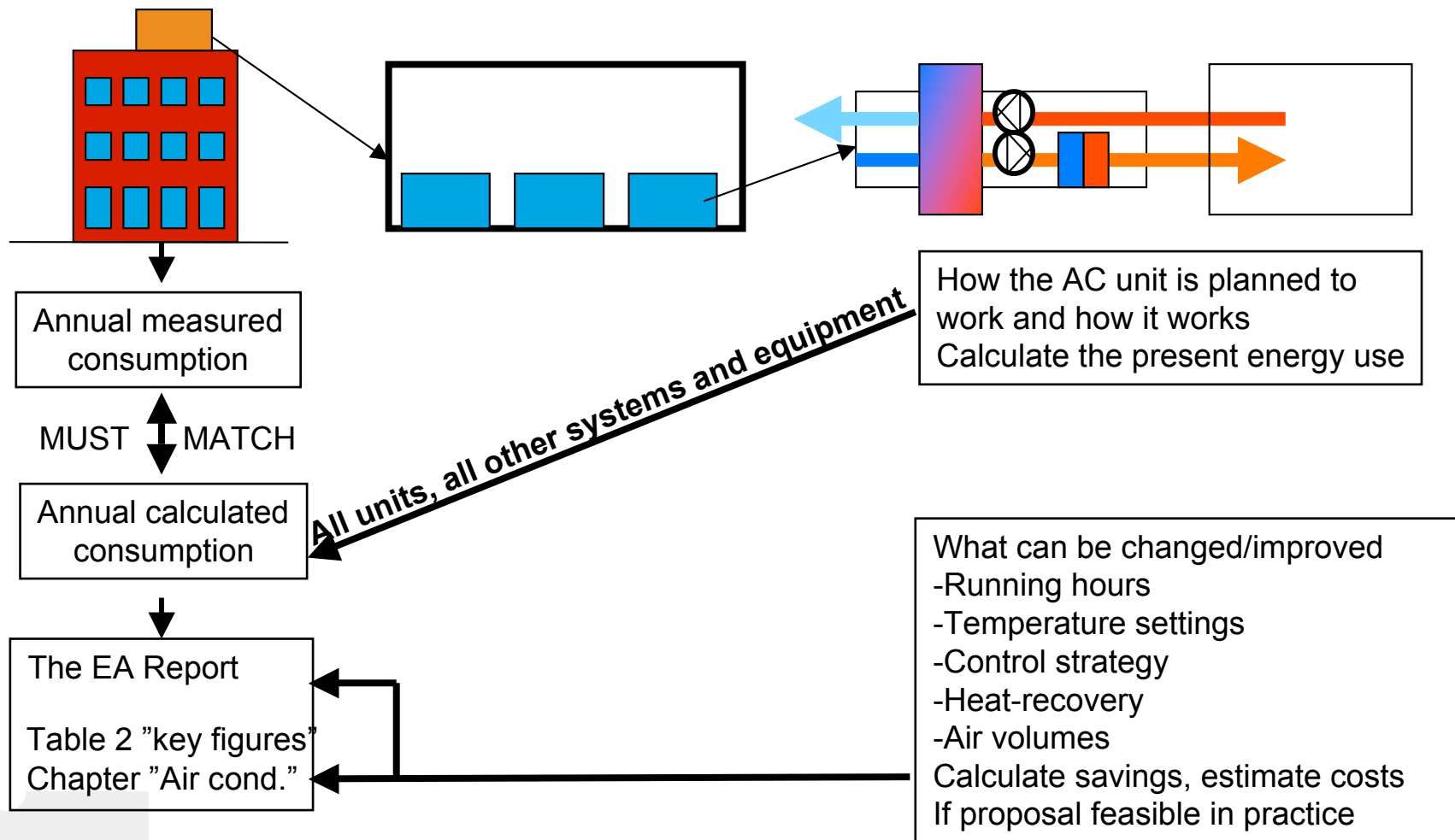

How the total energy consumption is divided to the sectors?

Darker areas are representing the share of the total energy consumption belonging to the companies/communities who have joined the sector's agreement scheme (=60% of the total energy consumption in Finland)

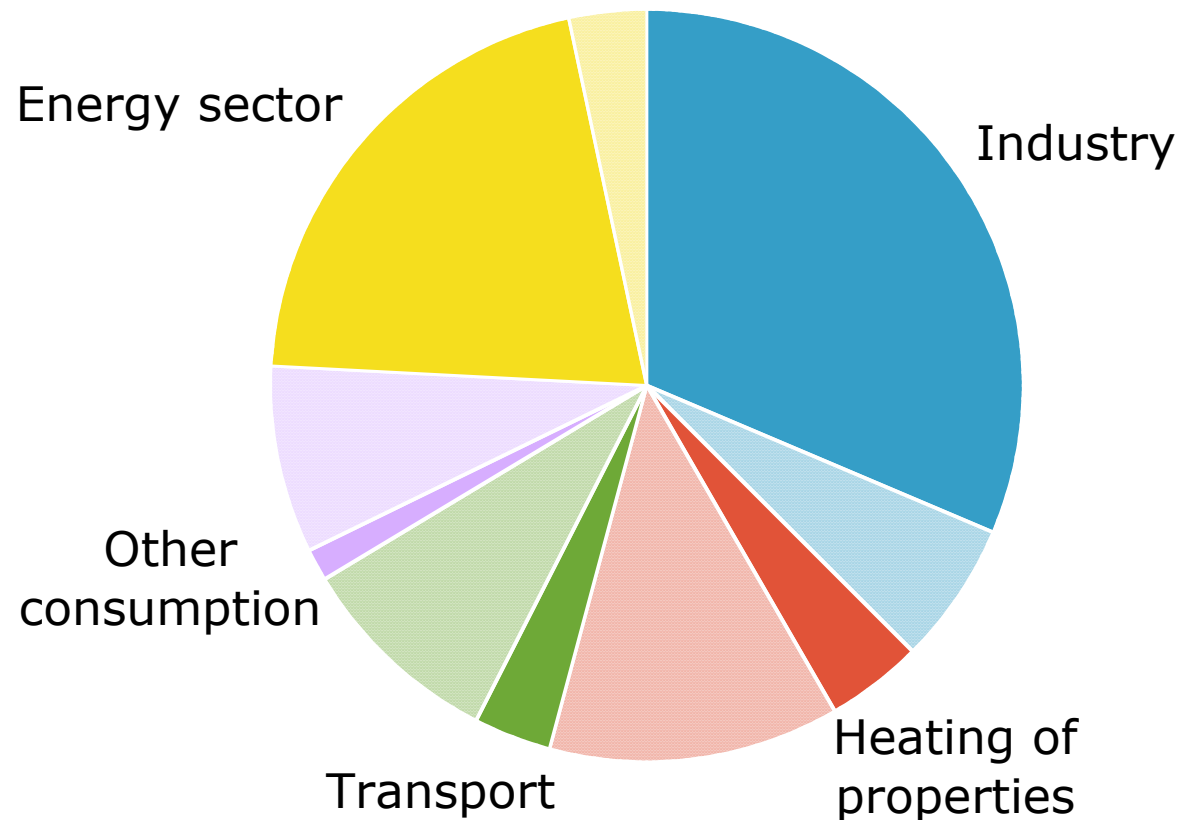

Not only to get the figure "1 TWh/a"

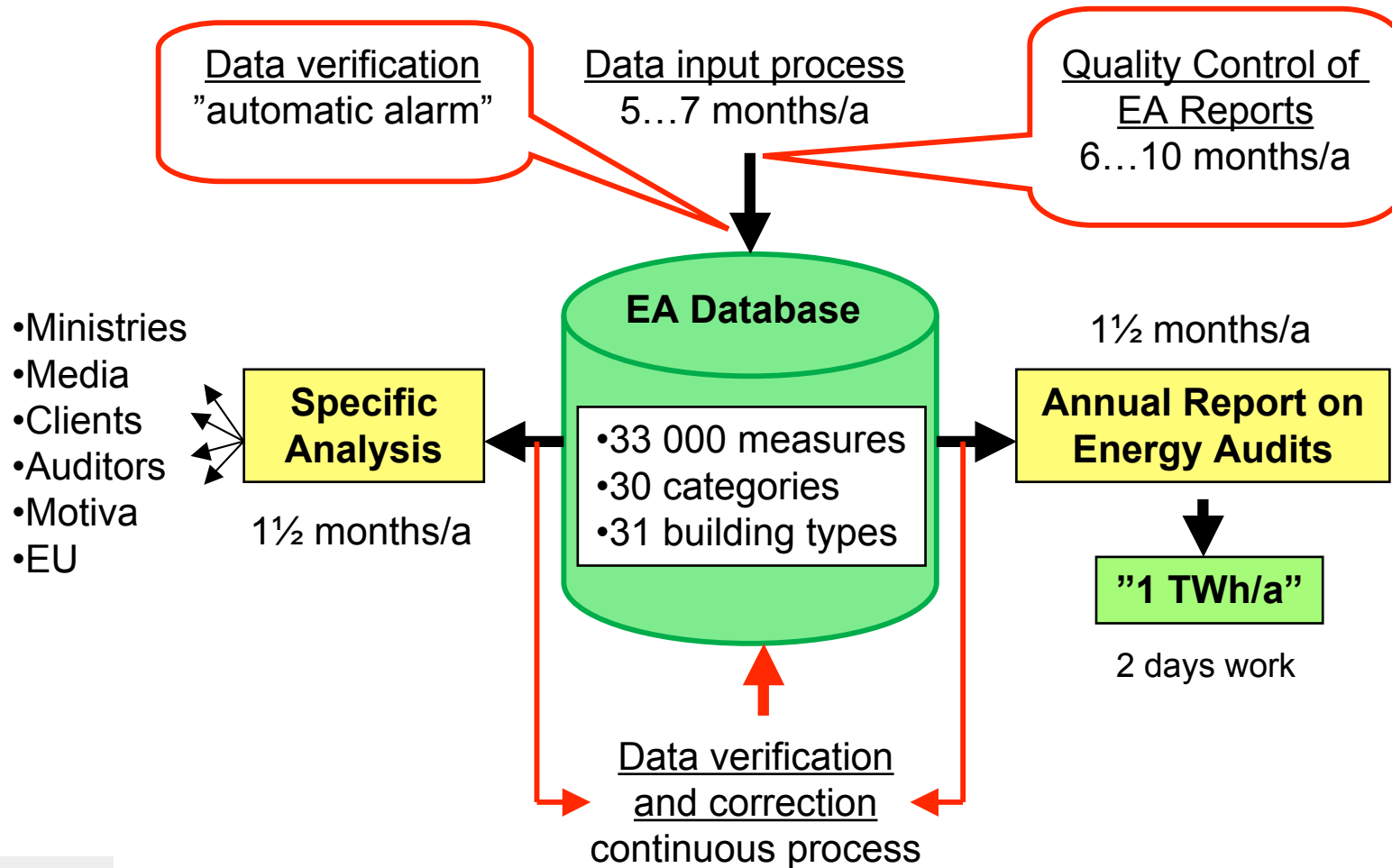

Actual status of implementation of 13 325 energy saving measures from 1 681 energy audits reported 2000-2005

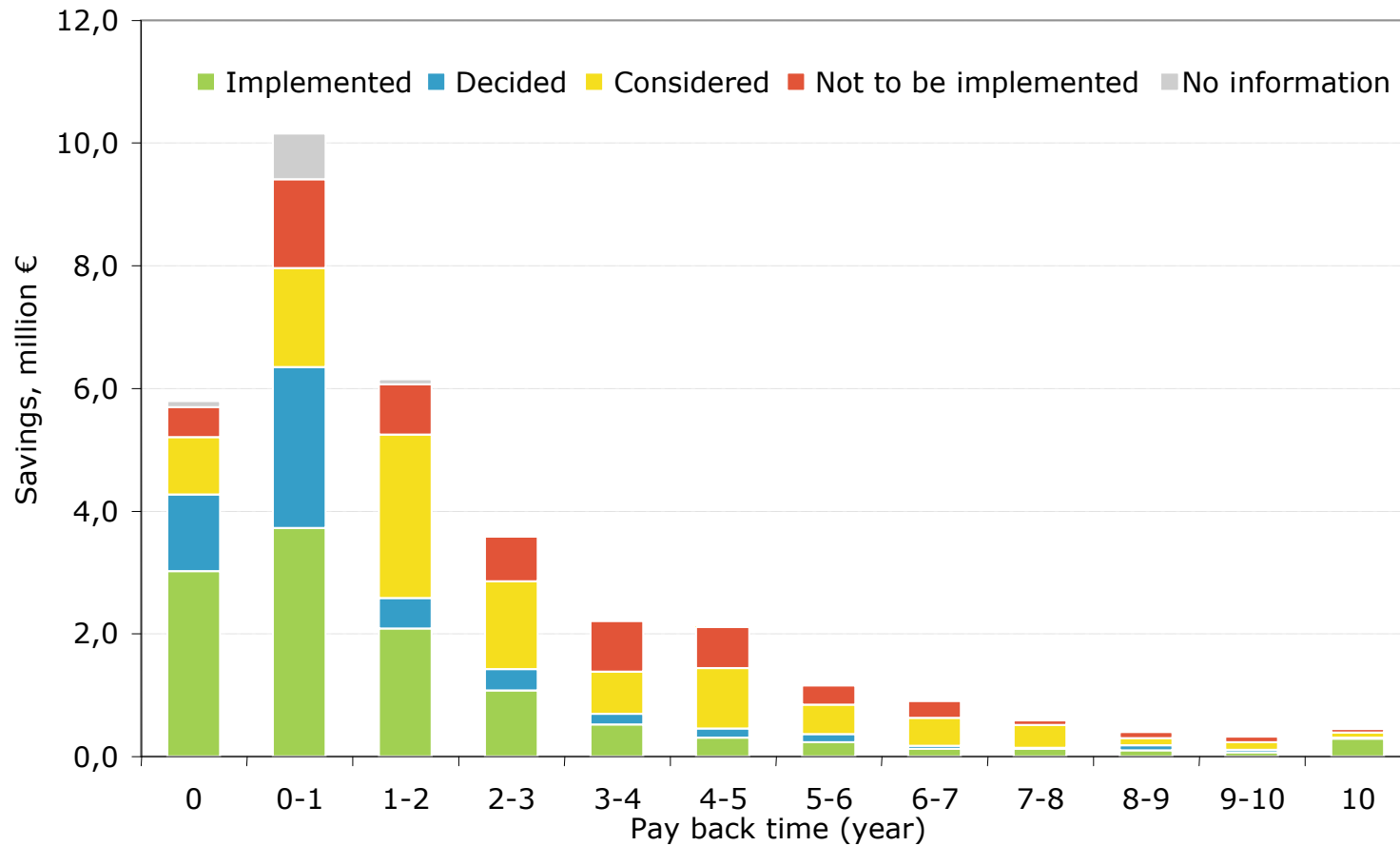

The profitability of the proposed saving measures in the service sector energy audits 1998-2003 (total 11,1 milj. €)

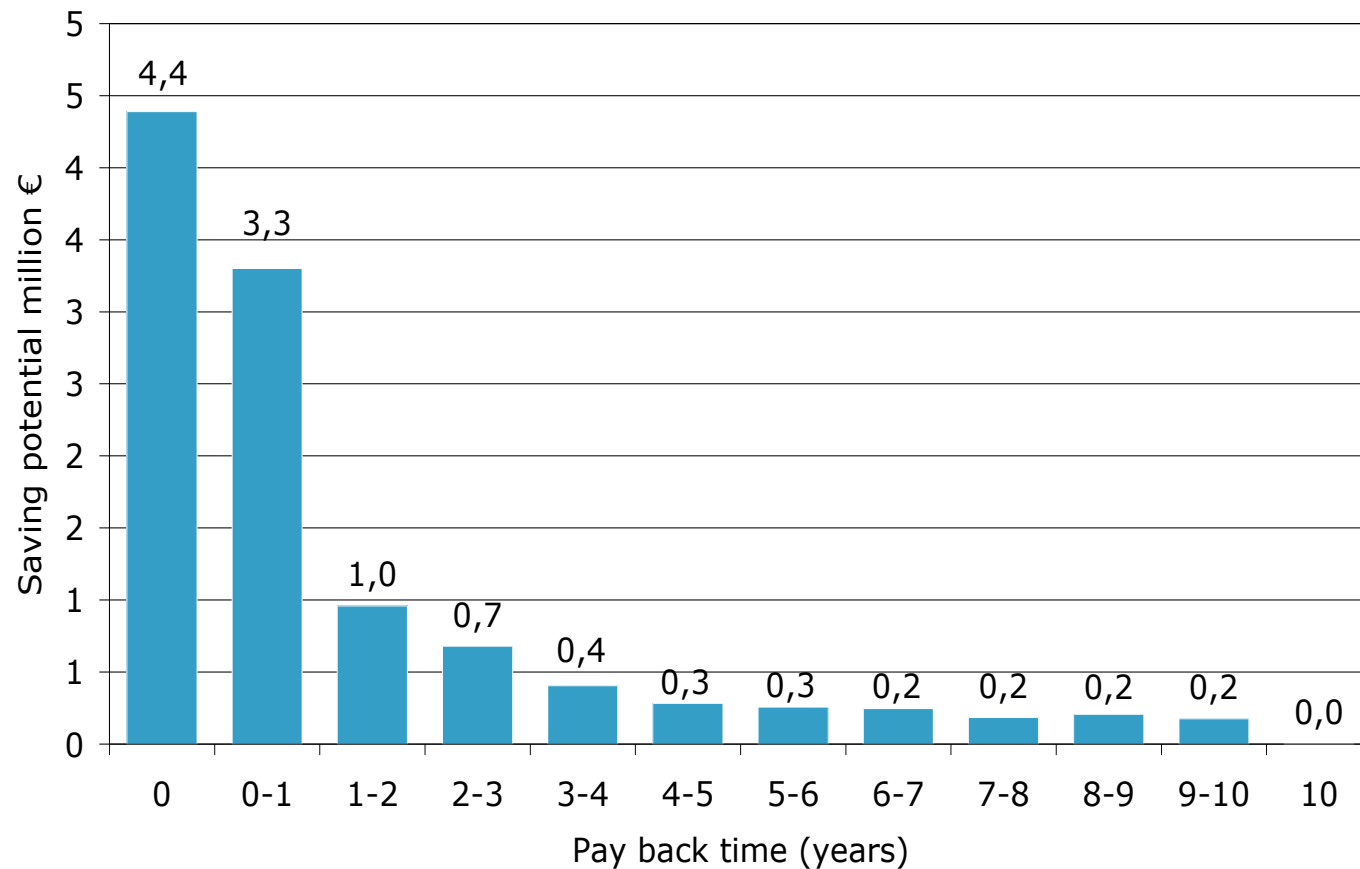

The profitability of the proposed saving measures in the industry and energy sector energy audits 1998-2003

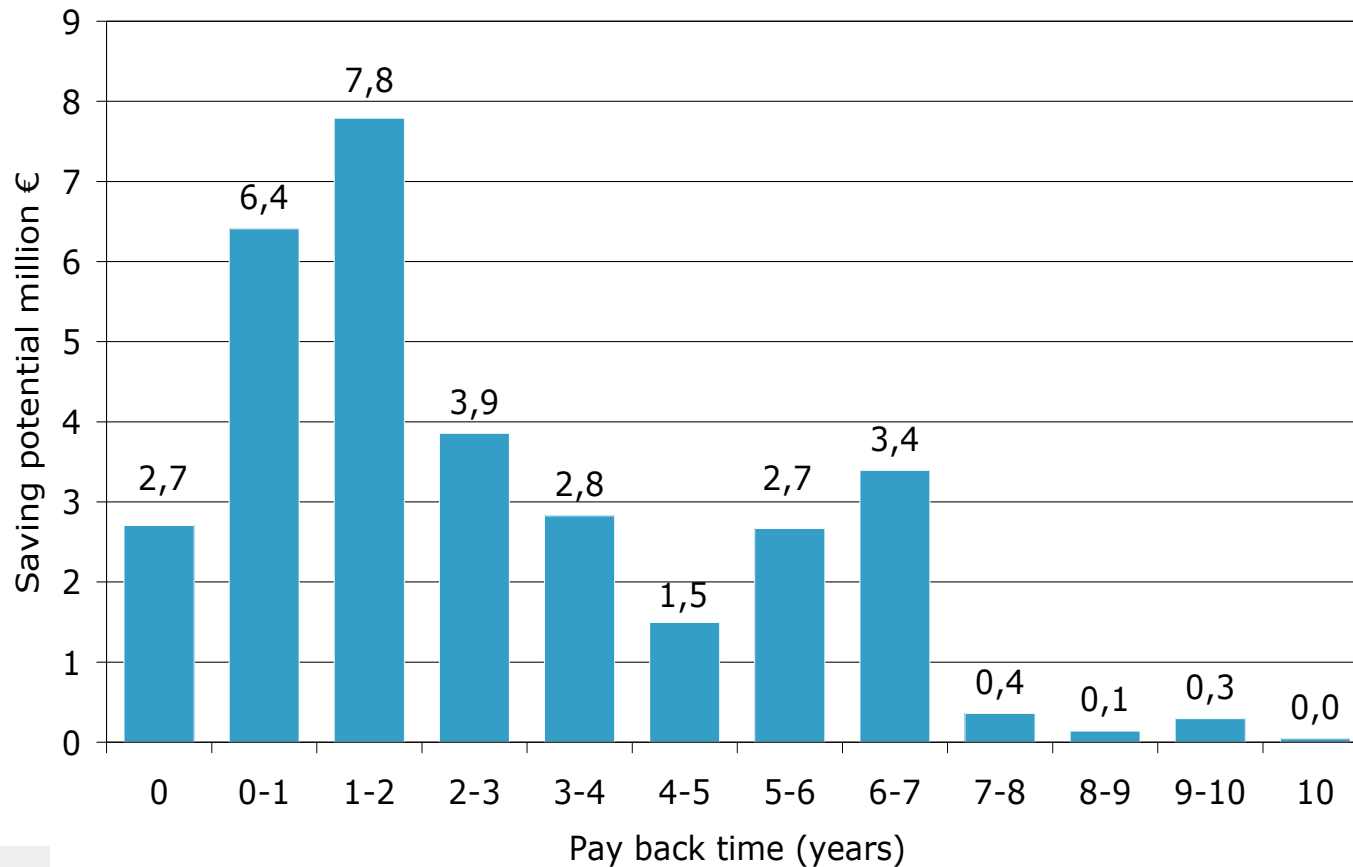

How the data collection is organised? Checked, re-checked, filed and reported

ENERGY AUDITS

